



POWERING INNOVATION THAT DRIVES HUMAN ADVANCEMENT

© 2025 ANSYS, Inc. or its affiliated companies
Unauthorized use, distribution, or duplication is prohibited.

Getting Started with HFSS: Bandpass Filter



ANSYS, Inc.
Southpointe
2600 Ansys Drive
Canonsburg, PA 15317
ansysinfo@ansys.com
<https://www.ansys.com>
(T) 724-746-3304
(F) 724-514-9494

Release 2025 R1
January 2025

ANSYS, Inc. and ANSYS
Europe, Ltd. are UL registered
ISO 9001:2015 companies.

Copyright and Trademark Information

© 1986-2025 ANSYS, Inc. Unauthorized use, distribution or duplication is prohibited.

ANSYS, Ansys Workbench, AUTODYN, CFX, FLUENT and any and all ANSYS, Inc. brand, product, service and feature names, logos and slogans are registered trademarks or trademarks of ANSYS, Inc. or its subsidiaries located in the United States or other countries. Icem CFD is a trademark used by ANSYS, Inc. under license. All other brand, product, service and feature names or trademarks are the property of their respective owners. FLEXIm and FLEXnet are trademarks of Flexera Software LLC.

Disclaimer Notice

THIS ANSYS SOFTWARE PRODUCT AND PROGRAM DOCUMENTATION INCLUDE TRADE SECRETS AND ARE CONFIDENTIAL AND PROPRIETARY PRODUCTS OF ANSYS, INC., ITS SUBSIDIARIES, OR LICENSORS. The software products and documentation are furnished by ANSYS, Inc., its subsidiaries, or affiliates under a software license agreement that contains provisions concerning non-disclosure, copying, length and nature of use, compliance with exporting laws, warranties, disclaimers, limitations of liability, and remedies, and other provisions. The software products and documentation may be used, disclosed, transferred, or copied only in accordance with the terms and conditions of that software license agreement.

ANSYS, Inc. and ANSYS Europe, Ltd. are UL registered ISO 9001: 2015 companies.

U.S. Government Rights

For U.S. Government users, except as specifically granted by the ANSYS, Inc. software license agreement, the use, duplication, or disclosure by the United States Government is subject to restrictions stated in the ANSYS, Inc. software license agreement and FAR 12.212 (for non-DOD licenses).

Third-Party Software

See the legal information in the product help files for the complete Legal Notice for Ansys proprietary software and third-party software. If you are unable to access the Legal Notice, please contact ANSYS, Inc.

Conventions Used in this Guide

Please take a moment to review how instructions and other useful information are presented in this documentation.

- Procedures are presented as numbered lists. A single bullet indicates that the procedure has only one step.
- Bold type is used for the following:
 - Keyboard entries that should be typed in their entirety exactly as shown. For example, “**copy file1**” means you must type the word **copy**, then type a space, and then type **file1**.
 - On-screen prompts and messages, names of options and text boxes, and menu commands. Menu commands are often separated by greater than signs (>). For example, “click **HFSS > Excitations > Assign > Wave Port.**”
 - Labeled keys on the computer keyboard. For example, “Press **Enter**” means to press the key labeled **Enter**.
- Italic type is used for the following:
 - Emphasis.
 - The titles of publications.
 - Keyboard entries when a name or a variable must be typed in place of the words in italics. For example, “**copy filename**” means you must type the word **copy**, then type a space, and then type the name of the file.
- The plus sign (+) is used between keyboard keys to indicate that you should press the keys at the same time. For example, “Press Shift+F1” means to press the **Shift** key and, while holding it down, press the **F1** key also. You should always depress the modifier key or keys first (for example, Shift, Ctrl, Alt, or Ctrl+Shift), continue to hold it/them down, and then press the last key in the instruction.

Accessing Commands: *Ribbons*, *menu bars*, and *shortcut menus* are three methods that can be used to see what commands are available in the application.

- The *Ribbon* occupies the rectangular area at the top of the application window and contains multiple tabs. Each tab has relevant commands that are organized, grouped, and labeled. An example of a typical user interaction is as follows:

"Click **Draw > Line**"



This instruction means that you should click the **Line** command on the **Draw** ribbon tab. An image of the command icon, or a partial view of the ribbon, is often included with the instruction.

- The *menu bar* (located above the ribbon) is a group of the main commands of an application arranged by category such File, Edit, View, Project, etc. An example of a typical user interaction is as follows:

"On the **File** menu, click the **Open Examples** command" means you can click the **File** menu and then click **Open Examples** to launch the dialog box.

- Another alternative is to use the *shortcut menu* that appears when you click the right-mouse button. An example of a typical user interaction is as follows:

"Right-click and select **Assign Excitation > Wave Port**" means when you click the right-mouse button with an object face selected, you can execute the excitation commands from the shortcut menu (and the corresponding sub-menus).

Getting Help: Ansys Technical Support

For information about Ansys Technical Support, go to the Ansys corporate Support website, <http://www.ansys.com/Support>. You can also contact your Ansys account manager in order to obtain this information.

All Ansys software files are ASCII text and can be sent conveniently by e-mail. When reporting difficulties, it is extremely helpful to include very specific information about what steps were taken or what stages the simulation reached, including software files as applicable. This allows more rapid and effective debugging.

Help Menu

To access help from the Help menu, click **Help** and select from the menu:

- **[product name] Help** - opens the contents of the help. This help includes the help for the product and its *Getting Started Guides*.
- **[product name] Scripting Help** - opens the contents of the *Scripting Guide*.
- **[product name] Getting Started Guides** - opens a topic that contains links to Getting Started Guides in the help system.

Context-Sensitive Help

To access help from the user interface, press **F1**. The help specific to the active product (design type) opens.

You can press **F1** while the cursor is pointing at a menu command or while a particular dialog box or dialog box tab is open. In this case, the help page associated with the command or open dialog box is displayed automatically.

Table of Contents

Table of Contents	Contents-1
1 - Introduction	1-1
Bandpass Filter Description	1-1
HFSS Design Environment	1-2
2 - Set Up the Project	2-1
Set General Options	2-2
Insert HFSS design	2-5
Set View Options	2-7
Set Model Units (in)	2-8
Verify Solution Type (Terminal)	2-9
3 - Create the 3D Model	3-1
Create the Enclosure	3-1
History Tree and Docked Properties Window	3-5
Create Feed1	3-6
Create FeedPin1	3-8
Create FeedProbe1	3-10
Create the Resonators	3-12
Create L1	3-12
Create L2	3-13
Method 1 – Draw Freehand and Revise its Properties	3-14
Method 2 – Copy L1 and Revise the New Object's Properties:	3-14
Create L3	3-15
Create L4	3-17
Assign Excitation	3-18
Create Remaining Objects by Duplication	3-21
Boundary Display (Optional)	3-24
4 - Set Up and Analyze the Model	4-1
Add Solution Setup and Frequency Sweep	4-1

Add HPC Analysis Setup	4-4
What HFSS Does with the HPC Configuration	4-8
Validate and Analyze the Bandpass Filter	4-9
Review Solution Data	4-10
Solving Time	4-10
Review the Profile Panel	4-10
Review the Convergence Panel	4-11
Review Matrix Data Panel	4-13
Review Mesh Statistics Panel	4-14
5 - Evaluate Results	5-1
Create S-Parameter vs. Frequency Plot	5-1
Compare S12 with S21	5-3
Change Plot Scale	5-4
Create Field Overlays	5-6
Modify Plot Attributes	5-8
Other Plot Attributes and Animating Results	5-11
Create a Frequency Animation	5-11
6 - Set Up and Run HFSS Multipaction Analysis	6-1
Duplicate HFSSDesign1	6-1
Imprint Feeds on Enclosure	6-2
Assign SEE Boundaries	6-4
Assign Charge Region Excitations	6-9
Add a Discrete Sweep	6-14
Add and Solve a Multipaction Analysis	6-15
Plot Particles versus Time	6-20
Create and Animate a Particle Overlay	6-21
Duplicate Multipaction Design and Add DC Bias	6-25
Solve Multipaction2 and Compare Results	6-28
7 - Optionally, Restore Legacy View Orientations	7-1

1 - Introduction

This Getting Started guide describes how to create, solve, and analyze a bandpass filter.

By following the steps in this guide, you will learn how to perform the following tasks in HFSS:

- Become familiar with the HFSS Design Environment
- Create a 3D geometric model, including conducting bodies and a surrounding vacuum region representing the bandpass filter enclosure
- Assign excitation
- Learn about High Performance Computing (HPC) options
- Analyze the model and review solution data,
- Create and modify a report (2D rectangular plot), including adjusting the plot scaling
- Create field overlays

Bandpass Filter Description

A bandpass filter allows frequencies of a certain range to pass through but attenuates those frequencies outside of the bandpass range. The figure below is an illustration of a model representing a bandpass filter and a volume of air surrounding it. The colors represent the electrical field intensity around the conductors.

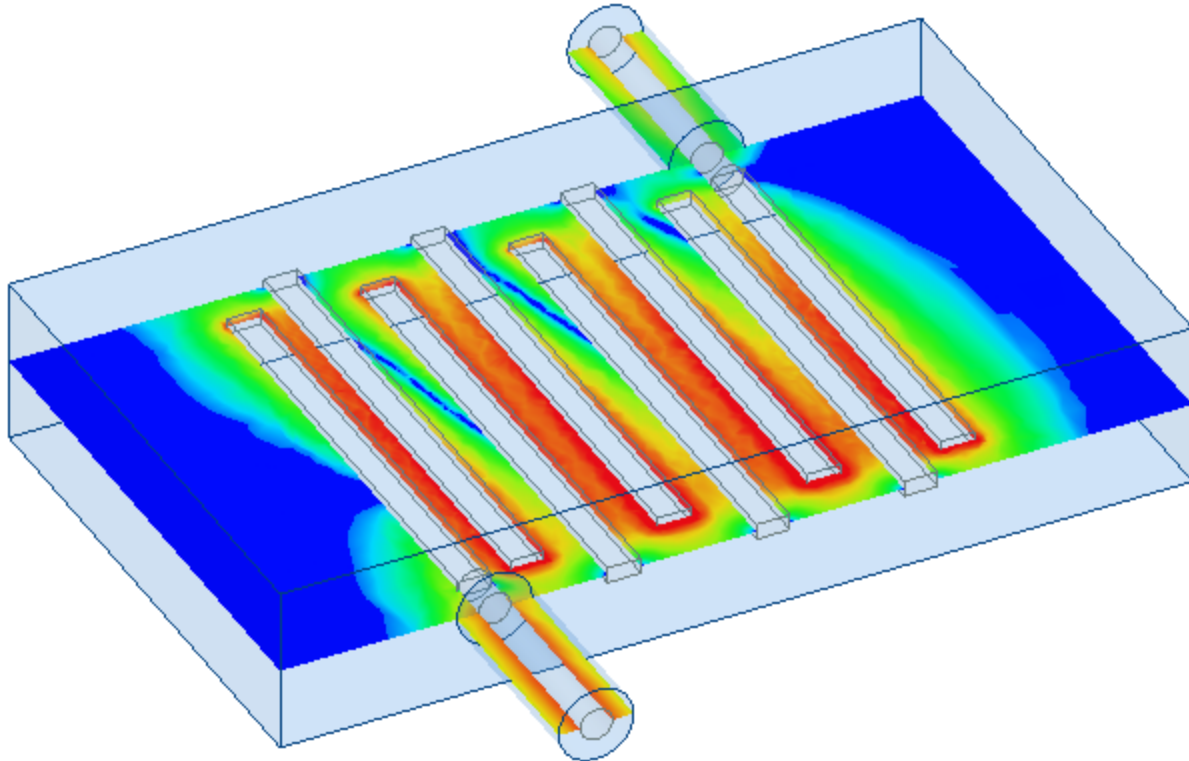

Figure 1-1: The Bandpass Filter Model

HFSS Design Environment

There are many features in HFSS that enable you to create this model. Some of these features are listed below:

- Three-dimensional (3D) solid modeling
- Primitives such as cylinders and boxes
- Modeling operations such as *Duplicate Around Axis*
- Boundaries and excitations
- Wave ports and terminals
- Design validation
- Solution setup and frequency sweep
- S-parameter plots
- Field Overlays to plot electromagnetic fields
- Two-dimensional (2D) and three-dimensional (3D) Field Plots

2 - Set Up the Project

This chapter includes the following sections:

- Launch Ansys Electronics Desktop
- Set General Options
- Insert HFSS design
- Set View Options
- Set the Model Units
- Verify the Solution Type

For convenience, store a shortcut of the Ansys Electronics Desktop application on your desktop.



1. Double-click the **Ansys Electronics Desktop** icon  to launch the application.

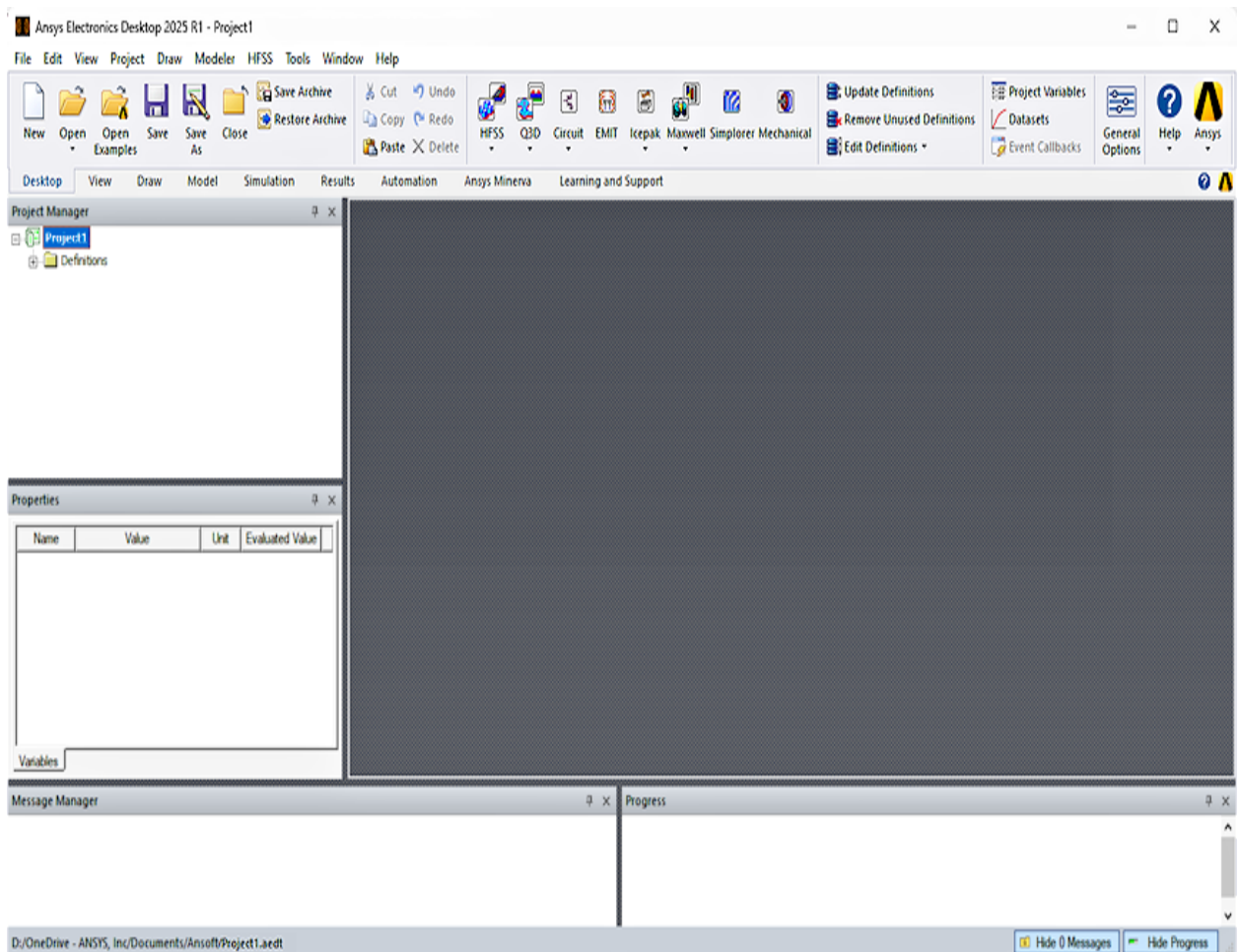





Figure 2-1: Ansys Electronics Desktop User Interface

Note:

If the project folder is missing, go to the **Desktop** ribbon tab and click  **New** to start a new project. If the *Project Manager* window does not appear, go to the **View** ribbon tab and enable it from the  **Docking Windows** drop-down menu.

Set General Options

Before you begin creating a design, configure some of the general options of HFSS:

1. Go to the **Desktop** ribbon tab and select  **General Options**.
The *Options* dialog box appears.
2. Expand the **HFSS** branch and select **Boundary Assignment**.

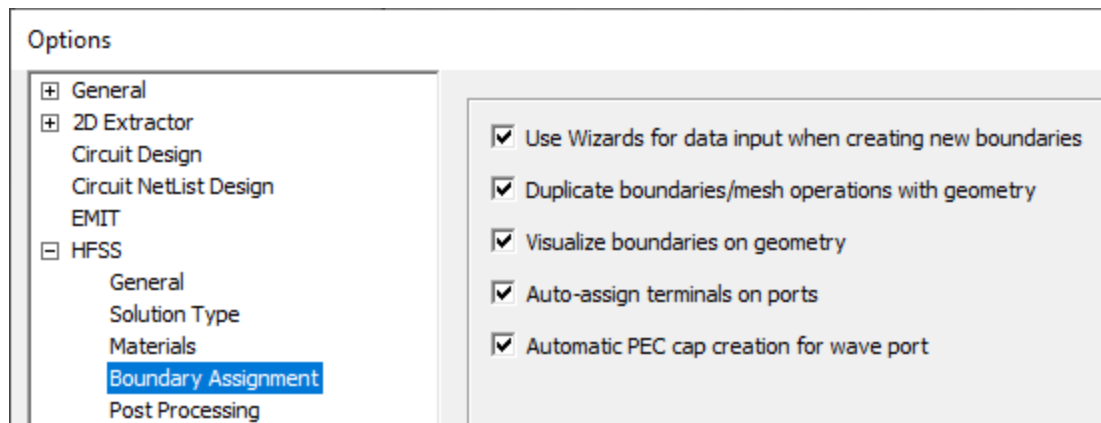

Figure 2-2: *Options* Window – HFSS Boundary Assignment Settings

3. Ensure all checkboxes on this panel are selected.
4. Expand the **3D Modeler** branch and select **Drawing**.

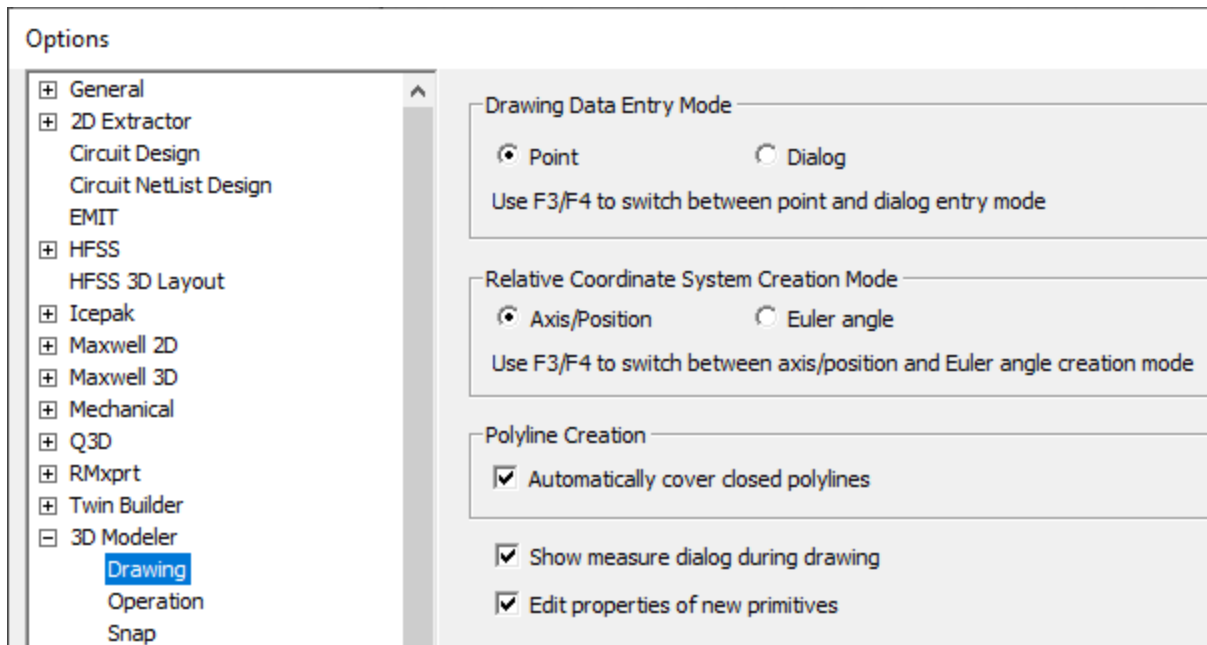

Figure 2-3: Options Window – 3D Modeler Drawing Settings

5. Select **Automatically cover closed polylines**.
6. Select **Edit properties of new primitives**.

Note:

This option causes a *Properties* dialog box to appear whenever you create a new object.

7. Under *3D Modeler*, expand the **Display** branch and select **Rendering**.
8. Clear **Use material appearance if available**, if this option is, selected and set **Default Transparency** to **0.85**.

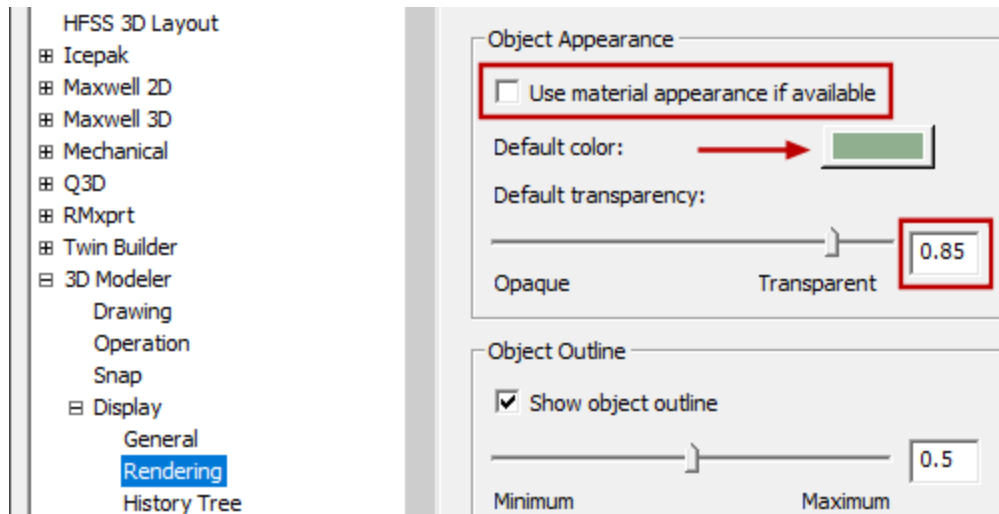

9. Click the **Default Color** button.

The *Color* dialog box appears, in which you will perform the following steps:

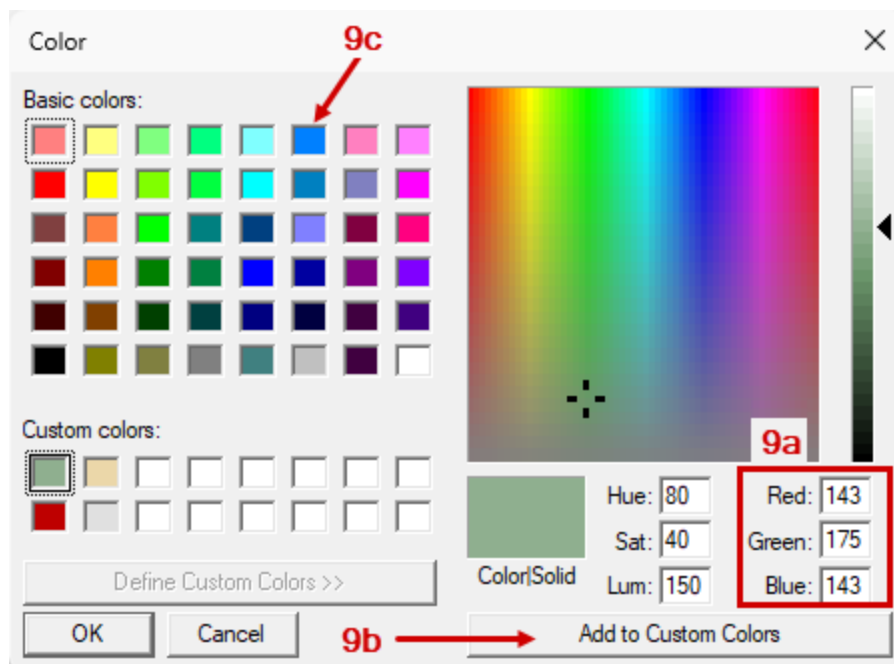

- a. Make a note of the current default color's *Red*, *Green*, and *Blue* (RGB) numeric values. Keep these values in a safe place if you wish to restore the original default color after completing this getting started guide.

The default RGB values for a clean installation of the Ansys Electronics Desktop application are 143, 175, and 143, respectively. However, your values may differ if previously customized.

- b. Optionally, click **Add to Custom Colors** to save the current default color to one of the boxes in the lower left corner of the dialog box for easier restoration.
- c. Select the **medium blue** swatch  (first row, third-last column, RGB values: 0, 128, 255).

This color, at 85% transparency, will be the new default choice when creating objects for which you do not use the predefined material appearance.

- d. Click **OK** to close the *Color* dialog box.
10. Click **OK** to close the *Options* dialog box.

Insert HFSS design

1. On the **Desktop** ribbon tab, click **HFSS** from the **HFSS** drop-down menu to include this design type in your project.

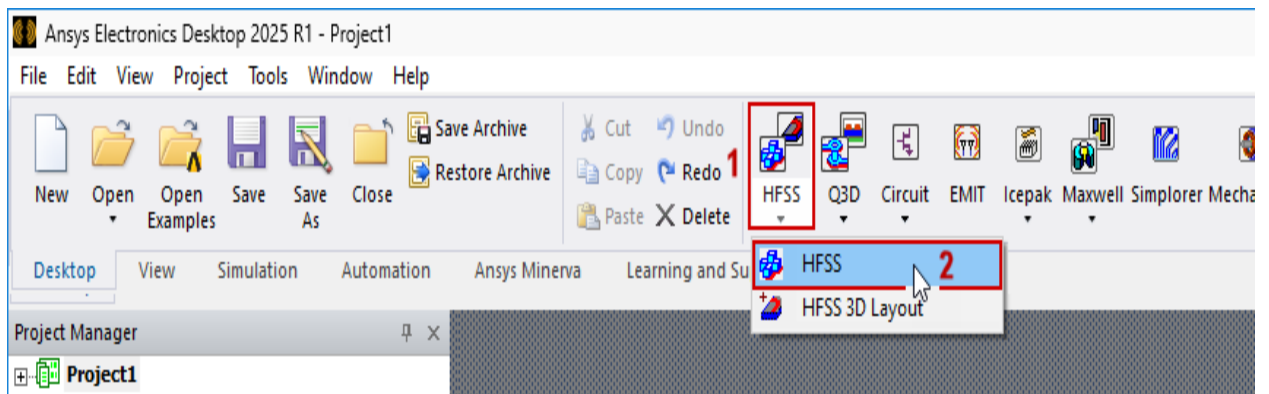

Figure 2-4: Insert HFSS Design – Command Location

Alternatively, you can simply click the HFSS icon (box number 1 above) without accessing the drop-down menu. Inserting an HFSS design is the default action when you click this icon.

An **HFSSDesignx** item appears in the Project Manager, the *Modeler* window appears, and the ribbon advances to the *Draw* tab.

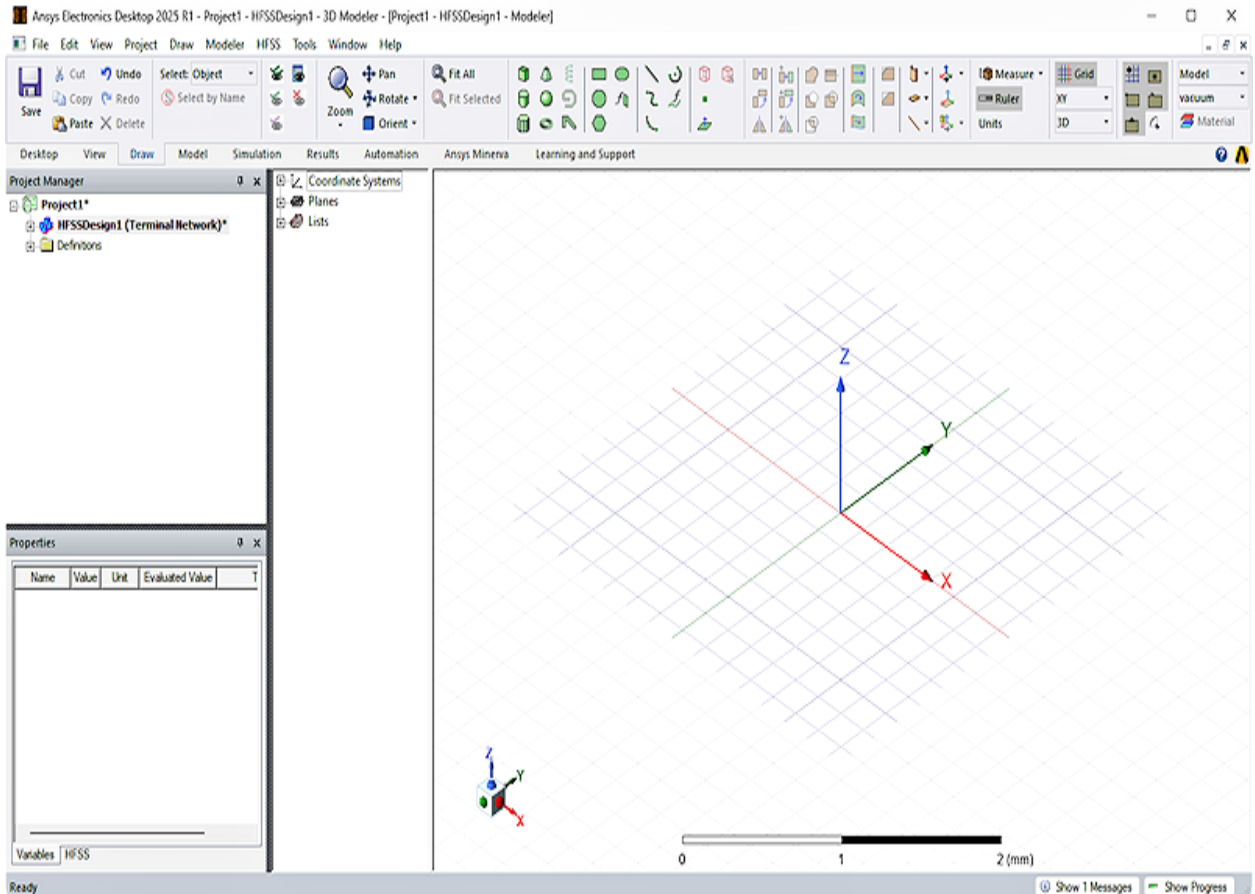



Figure 2-5: Electronics Desktop with the HFSS Design Type Added to the Project

2. Click **Project1** in the Project Manager, then:
 - a. Press **F2**
 - b. Rename your project to **Bandpass_Filter** and press **Enter**.

Note:

From the menu bar, click **View**, point to **Coordinate System**, and click any of the first three options in the submenu to adjust the displayed size of the coordinate axes. You can also control the visibility of the axes from this menu. Similarly, you can adjust grid visibility and style from the *Grid Spacing* dialog box that appears when you click **View > Grid Settings** from the menu bar.

- In any of the ribbon tabs, click  **Save** to save your project. Even though Ansys Electronics Desktop autosaves your model periodically (every ten edits, by default), it's a good idea to save your work frequently.

Set View Options

This getting started guide has been updated to use the new standard view orientations that were implemented in version 2024 R1 of the Ansys Electronics Desktop application. For consistency between your experience and the views and instructions contained in this guide, ensure that the *Enable Legacy View Orientation* option in the *3D UI Options* dialog box is **cleared**, as follows:

- From the menu bar, click **View > Options**.

The *3D UI Options* dialog box appears.

- Clear **Enable Legacy View Orientation** if the option is selected:

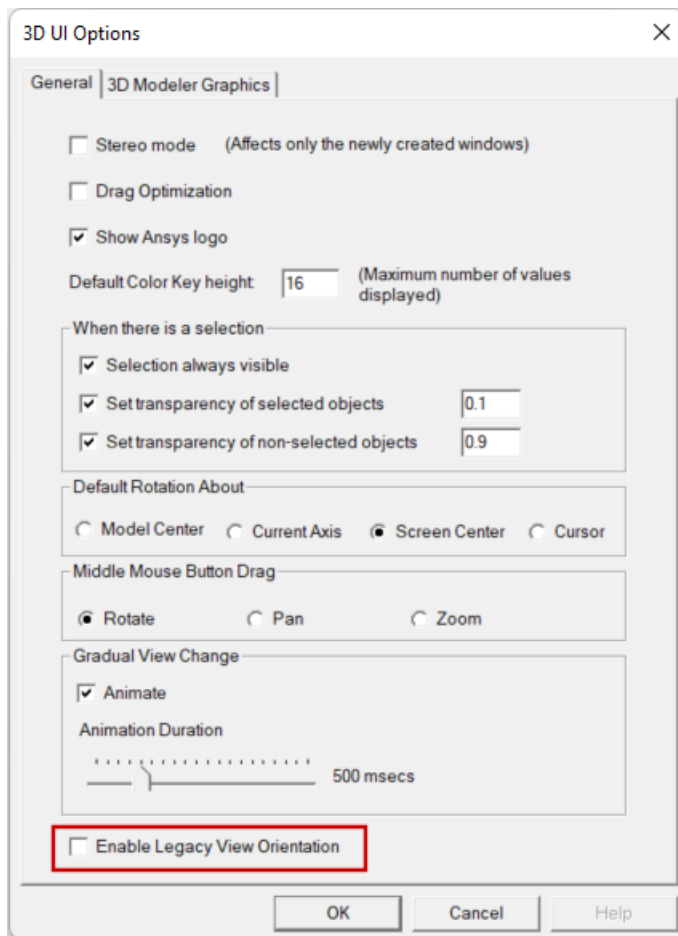



Figure 2-6: 3D UI Options Dialog Box

- Click **OK**.

Changing the view orientation option does not change the model viewpoint that was in effect at the time.

4. On the **Draw** ribbon tab, click  **Orient** to ensure that you are looking at the *Isometric* view, which is the current default view orientation.

You do not have to select *Isometric* from the *Orient* drop-down menu. The default view appears when you click *Orient*.

Although the *Enable Legacy View Orientation* option can only be accessed once a design is added to a project, it is a global option. Your choice is retained for all future program sessions, projects, and design types that use the 3D Modeler or that produce 3D plots of results.

At the end of this guide, you will be prompted to restore your preference, if you prefer to continue using the legacy view orientations that were in effect for 2023 R2 and earlier versions of the software.

For a comparison of the legacy and current view orientations, search for "View Options: 3D UI Options" in the HFSS help. Additionally, views associated with **Alt + double-click** zones have been redefined. The current orientations are shown in the help topic, "Changing the Model View with Alt+Double-Click Areas."

Set Model Units (in)

Define the model units as follows:

1. On the **Draw** ribbon tab, click **Units**.

The *Set Model Units and Max Extents* dialog box appears.

2. Select **in** (inches) from the **Select units** drop-down menu.

Keep **Rescale to new units** cleared and leave the **Advanced** option cleared, keeping the default model extents of +/-10000 length units.

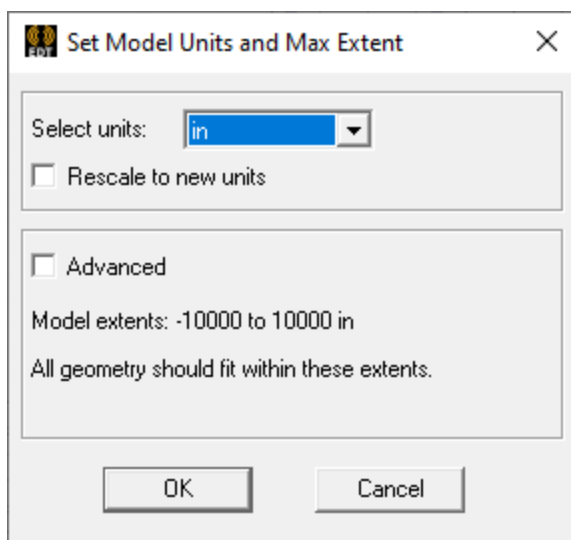

Figure 2-7: Set Model Units and Max Extents Dialog Box

3. Click **OK**.

Verify Solution Type (Terminal)

Specify the design's solution type as follows:

1. On the menu bar, click **HFSS > Solution Type**.

The *Solution Type* dialog box appears.

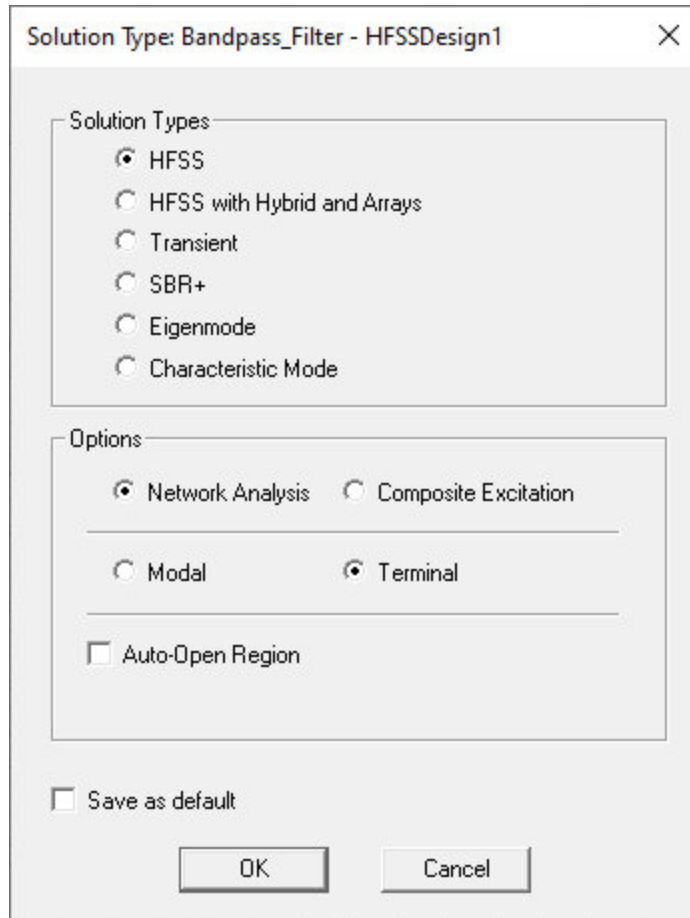
**Figure 2-8: Solution Type Dialog Box**

2. Ensure that **HFSS**, **Terminal**, and **Network Analysis** are selected. Leave **Auto-Open Region** cleared.
3. Click **OK**.

Note:

The *Terminal* solution type calculates the terminal-based S-parameters of multi-conductor transmission line ports. The S-matrix solutions are expressed in terms of terminal voltages and currents.

3 - Create the 3D Model

This chapter includes the following sections:

- Create the Enclosure (vacuum region)
- Create Feed1 (coax outer diameter)
- Create FeedPin1 (coax conductor)
- Create FeedProbe1
- Create the Resonators
- Assign Excitation
- Create Remainder of Model by Duplication
- Boundary Display (Optional)

The 3-D Model of the bandpass filter is made up of multiple geometrical parts, as listed above.

For the first two objects (Enclosure and Feed1), assign *vacuum* as the material. For all other parts, assign the material *pec* (perfect electrical conductor). Each duplicated parts will retain the same material assignment as the part from which it is copied.

Note:

- You can enter the coordinates and dimensions (height, radii, etc.), in the text boxes at the bottom of the application while building the geometric objects. However, you may find it more convenient to draw the objects freehand and then edit their properties. The latter method is used in this exercise.
- If you want you can adjust the views of your coordinate system axes and grid from the **View** menu using the **Coordinate System** and **Grid Settings** options, respectively. These controls, with the exception of grid visibility, are not available from the ribbon.

Create the Enclosure

Normally, the region within which electromagnetic fields are calculated is a body comprised of the material vacuum or air. In the last topic of this guide, you will perform a multipaction analysis of the bandpass filter, which requires that the solution region be a vacuum.

To create the enclosure region, draw a box of any size freehand anywhere in the *Modeler* window and then adjust its properties, as follows:

1. On the **Draw** ribbon tab, click the  **Box** primitive.

The cursor changes to a snapping point indicator.

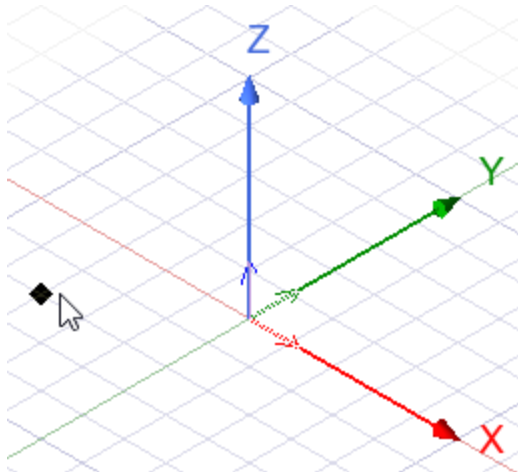

Figure 3-1: Snapping Point Indicator

2. Click anywhere in the 3D Modeler window to establish the starting point.
3. Drag your cursor along the **XY** plane, and click a second time to create the base:

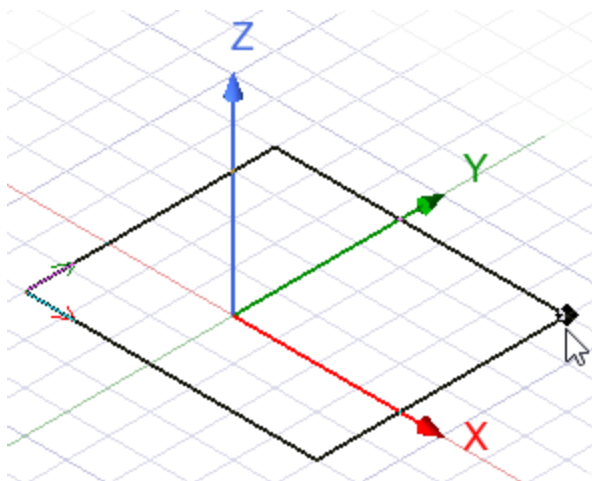

Figure 3-2: The Arrow is the Mini Z Axis.

4. Drag the cursor along the Z axis direction:

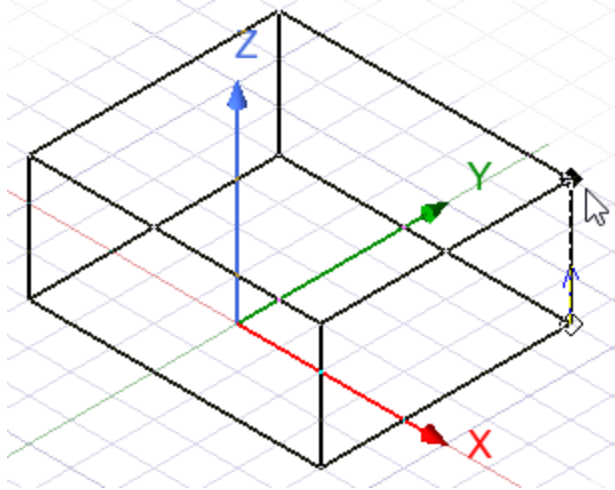

Figure 3-3: Box Height Being Dragged Upward

5. Click a third time to set the height and complete the box:

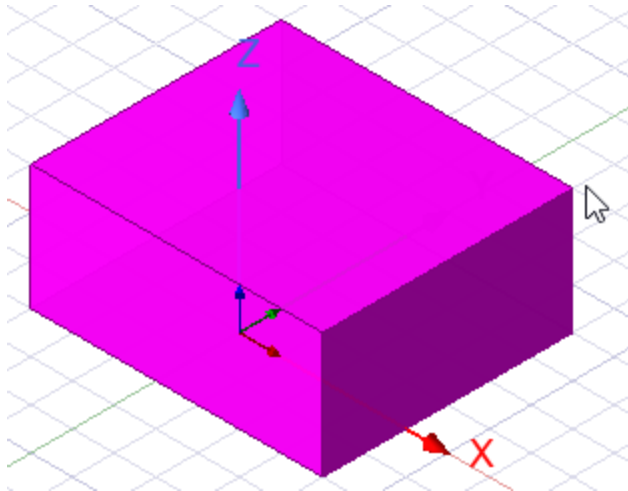

Figure 3-4: Box Drawn – After the Final Mouse Click

The *Properties* dialog box appears.

Note:

The automatic appearance of the *Properties* dialog box is controlled by one of the general options you previously set (specifically, the **Edit properties of new primitives** option under *3D Modeler > Drawing*).

6. On the **Command** tab, edit the **Value** table cells as shown in the following figure:

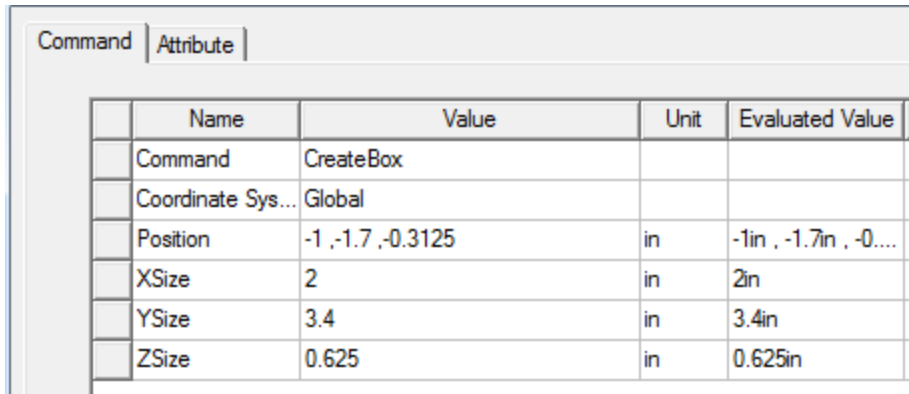

Command		Attribute		
Name	Value	Unit	Evaluated Value	
Command	CreateBox			
Coordinate Sys...	Global			
Position	-1 , -1.7 , -0.3125	in	-1in , -1.7in , -0....	
XSize	2	in	2in	
YSize	3.4	in	3.4in	
ZSize	0.625	in	0.625in	

Figure 3-5: Command Tab for the Enclosure Box

7. On the **Attribute** tab rename *Box1* to **Enclosure**.
8. Ensure that the selected **Material** is **vacuum**.
9. Verify that the color is medium blue and the **Transparency** to **0.85**, per the previously defined *Rendering* defaults.
10. Click **OK** to apply the new box properties and to close the *Properties* dialog box.
11. Click in the *Modeler* window's background area to deselect the enclosure.
12. Press **CTRL+D**, or click **Fit All** on the **Draw** ribbon tab, to fit the view in the Modeler window.

Note:

As you continue to build the model, use one of these two methods of fitting the model to the canvas area as needed.

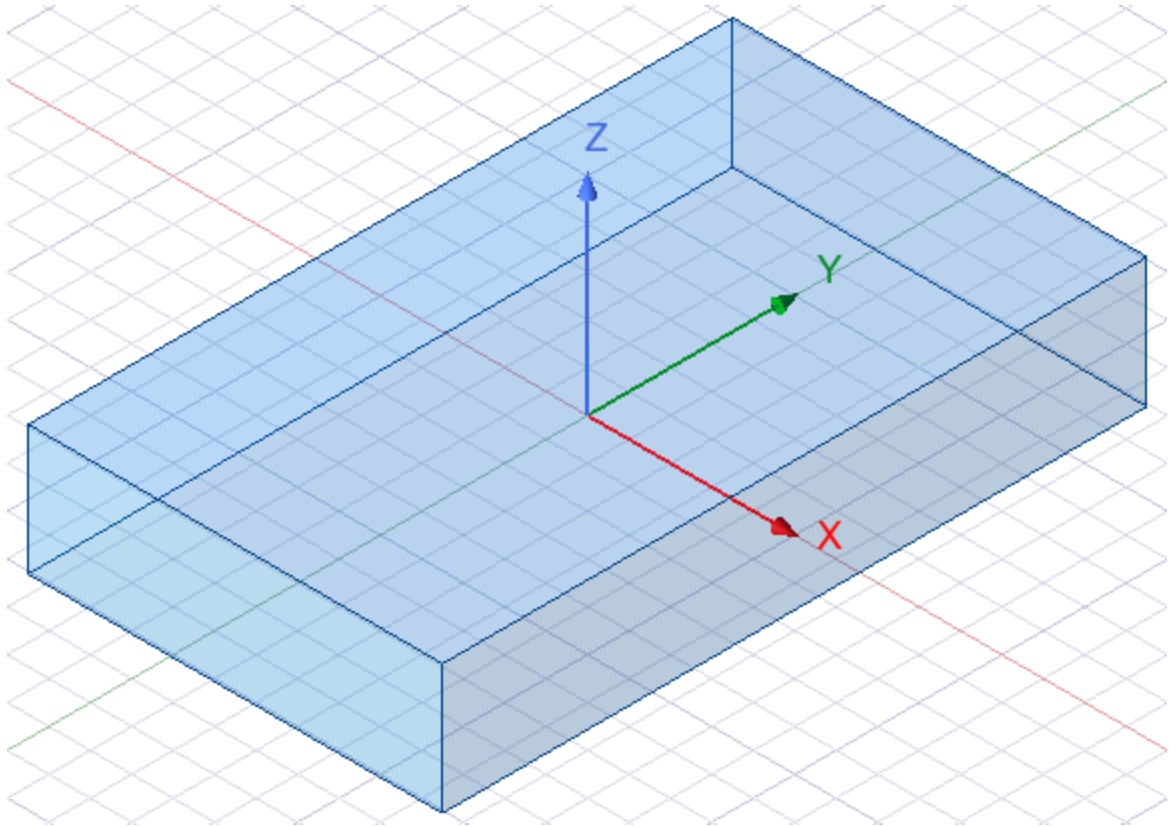
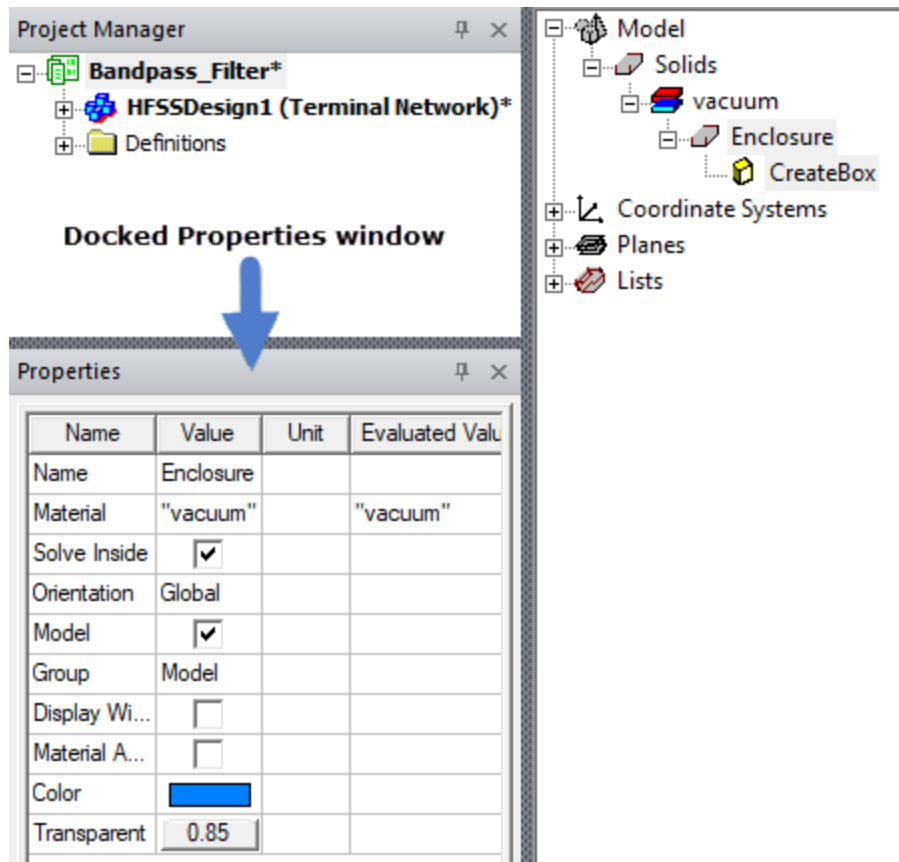

Figure 3-6: The Completed Enclosure Object

History Tree and Docked Properties Window

When you select a 3D or a 2D object in the history tree, its details can be readily viewed in the docked *Properties* window. For instance, if you select *Enclosure* in the History Tree, its details are displayed in the docked *Properties* window. To enable this window, go to the **View** ribbon tab and select **Properties** from the **Docking Windows** drop-down menu.

Figure 3-7: Docked *Properties* Window

Create Feed1

Feed1 is a cylindrical object representing the vacuum portion of the feed coax. You will add a conductor at the center of the coax in a later procedure.

To create Feed1, draw a cylinder freehand and then adjust its properties, as described below:

1. Click the **Draw** tab and select **YZ** under **Grid** to set the drawing plane.

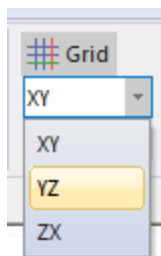

The active plane changes to YZ.

2. On the **Draw** ribbon tab, click the **Cylinder** primitive and create the cylinder any size and anywhere in the Modeler window.

**Note:**

In this case, draw the circular cross-section first and then draw the length.

3. On the **Command** tab of the *Properties* dialog box, edit the fields as shown in the following figure:

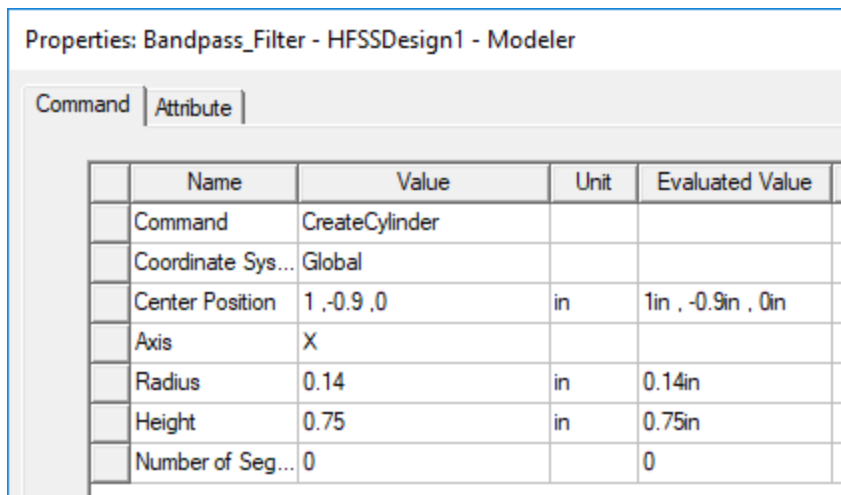

Figure 3-8: Command Tab – Properties for Feed1

4. On the **Attribute** tab rename the cylinder to **Feed1** and ensure that the material **vacuum** is assigned.
5. Click **OK** to complete the cylinder.

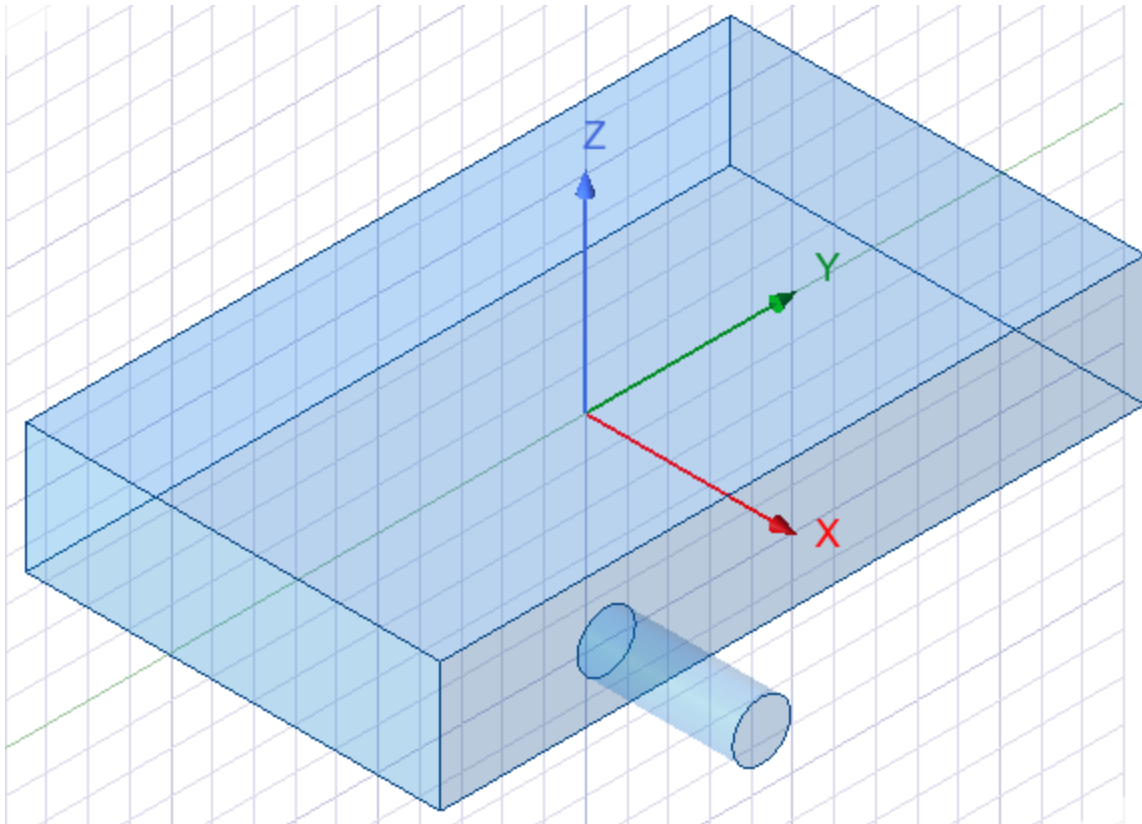

Figure 3-9: Feed1 Created

Create FeedPin1

You can pick a different material from the library before creating new geometry. This technique is convenient when you are going to create several objects of the same material.

After choosing the desired material, create the feed pin, which is the conductor at the center of the feed coax. Draw a cylinder freehand and then modify its properties.

You do not need to subtract the feed pin from the previously created feed object. The solver will perform implicit subtraction, removing the conductor volume from the vacuum object where they overlap.

1. On the **Draw** ribbon tab, click **Select** from the **Default material** drop-down menu.

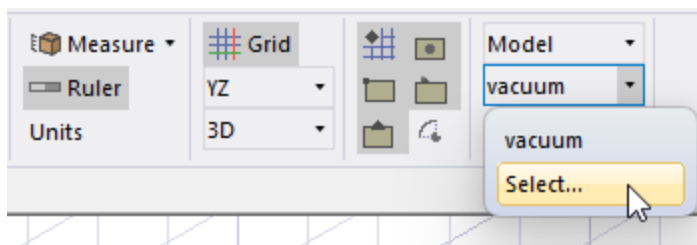

The *Select Definition* dialog box appears:

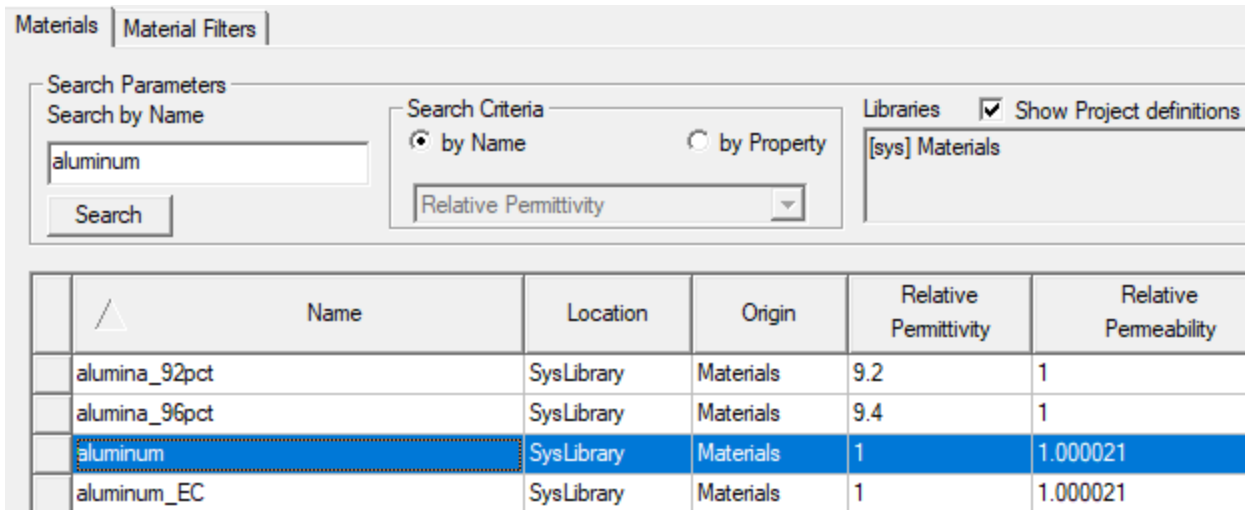

Figure 3-10: Select Definition Dialog Box

Then, do the following:

- a. Type **aluminum** in the **Search by Name**. The materials list scrolls to the first *aluminum* material, and it is selected.
- b. Click **OK** to accept the material selection.

The default material is set to *aluminum* and the *Select Definition* dialog box closes. All future objects you create in this project will default to this material until you change the selection again.

2. Draw a cylinder freehand and edit the fields on the **Command** tab of the *Properties* dialog box, as shown in the following figure:

	Name	Value	Unit	Evaluated Value
	Command	CreateCylinder		
	Coordinate Sys...	Global		
	Center Position	1, -0.9, 0	in	1in, -0.9in, 0in
	Axis	X		
	Radius	0.06	in	0.06in
	Height	0.75	in	0.75in
	Number of Seg...	0		0

Figure 3-11: FeedPin1 Properties – Command Tab

3. On the **Attribute** tab:

- a. Rename the object as **FeedPin1**.
- b. Select **Material Appearance**.
- c. Click **OK**.

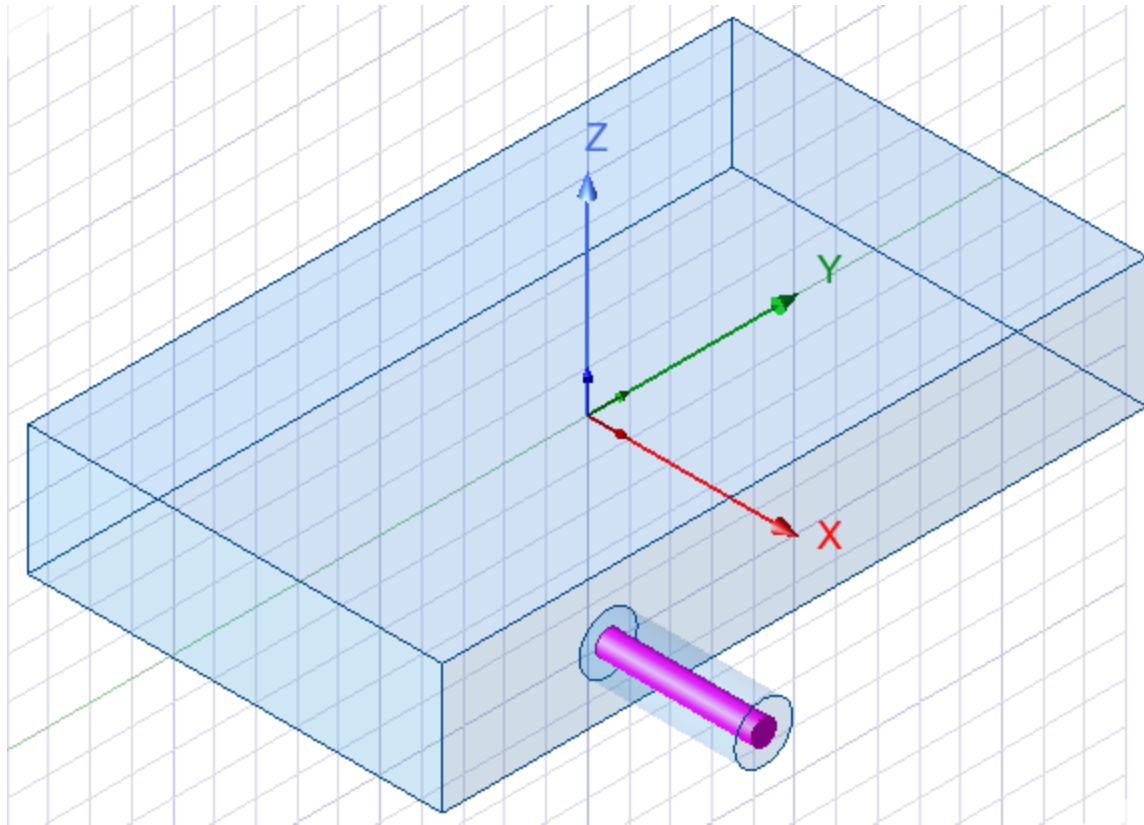

Figure 3-12: FeedPin1 Created.

Create FeedProbe1

The feed probe connects *FeedPin1* to the first resonator, *L1*, which you will draw in the next topic.

Note:

Alternatively, you could have created *FeedPin1* longer, to extend all the way to *L1*, eliminating the necessity of the feed probe. However, boundary errors would occur because the extended feed pin would cross through the outer boundaries of both *Feed1* and *Enclosure*. To prevent the errors, you would have to subtract *FeedPin1* from *Feed1* and *Enclosure* (to eliminate the overlap).

The feed probe, on the other hand, is fully encompassed by the enclosure by design. Therefore, implicit subtraction takes care of the object overlap, neither the feed pin nor feed probe crosses the enclosure boundary, and no boundary errors occur.

Create *FeedProbe1* as follows:

1. Draw a cylinder freehand and edit the fields on the **Command** tab of the *Properties* dialog box, as shown in the following figure:

	Name	Value	Unit	Evaluated Value
	Command	CreateCylinder		
	Coordinate Sys...	Global		
	Center Position	1, -0.9, 0	in	1in, -0.9in, 0in
	Axis	X		
	Radius	0.06	in	0.06in
	Height	-0.15	in	-0.15in
	Number of Seg...	0		0

Figure 3-13: Coax FeedProbe1 Properties – Command Tab

2. On the **Attribute** tab:
 - a. Rename the object as **FeedProbe1**.
 - b. Select **Material Appearance**.
 - c. Click **OK**.

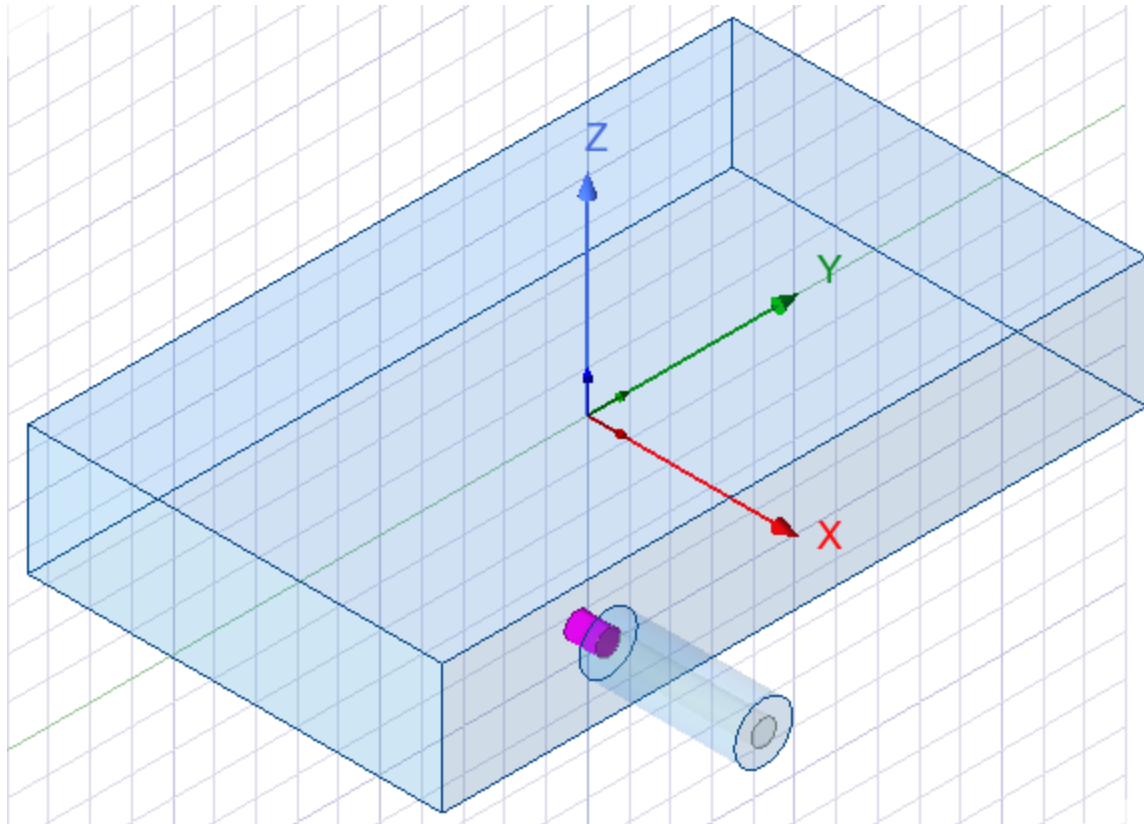

Figure 3-14: FeedProbe1 Added.

Create the Resonators

Draw four resonators for this model. For each resonator, draw a box freehand and then size and place it appropriately in the structure you have drawn up to this point.

There are a total of eight resonators in the bandpass filter—four, you create manually, and the other four (along with the feed and probe objects), you make by duplicating the manually created objects.

The resonators are the heart of the bandpass filter. The varying gaps between them and the alternating axial offset of each resonator produce the desired bandpass filter behavior (allowing frequencies of a certain range to pass freely while attenuating frequencies outside of the target range).

Create L1

1. Draw a box freehand and edit the fields in the **Command** tab of the *Properties* dialog box, as shown in the following figure:

Name	Value	Unit	Evaluated Value
Command	CreateBox		
Coordinate Sys...	Global		
Position	0.85 , -0.9625 , -0.03	in	0.85in , -0.9625in , -0.03in
XSize	-1.7	in	-1.7in
YSize	0.125	in	0.125in
ZSize	0.06	in	0.06in

Figure 3-15: Resonator L1 Properties – Command Tab

2. On the **Attribute** tab:
 - a. Rename the object as **L1**.
 - b. Select **Material Appearance**.
 - c. Click **OK**.

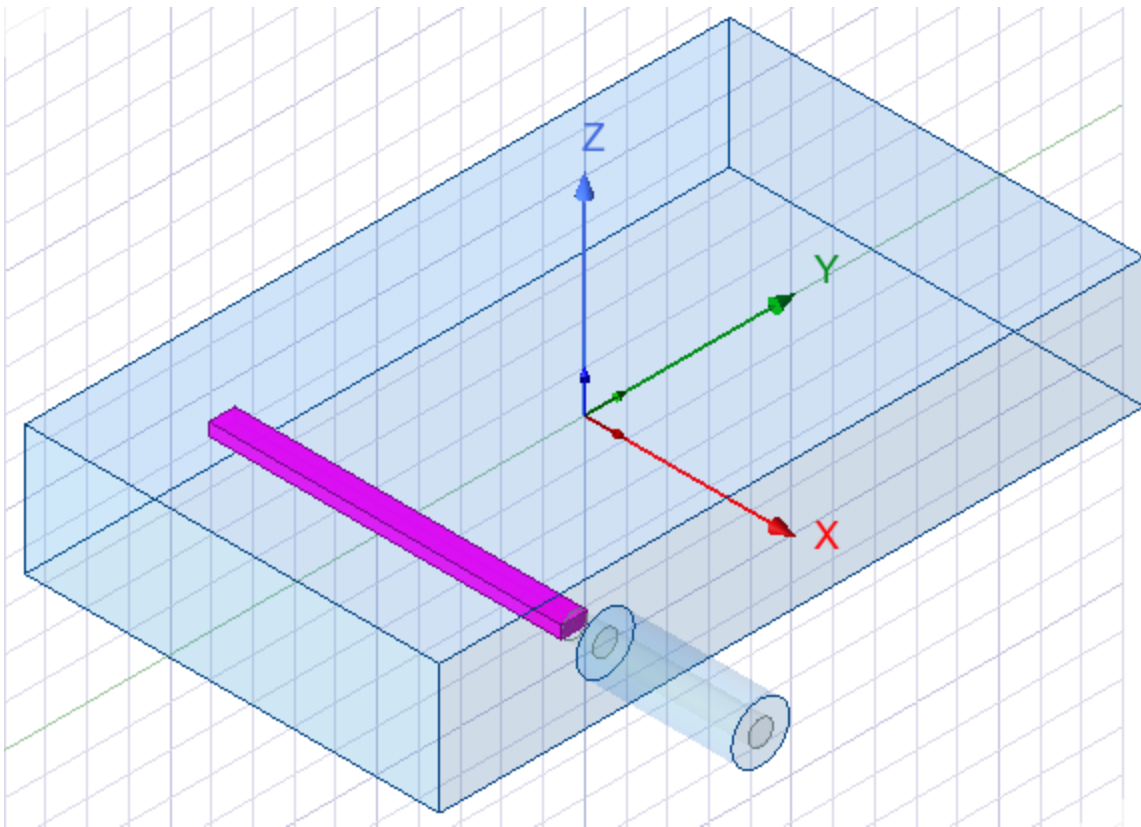

Figure 3-16: The First Resonator (L1) Created

Create L2

Let's look at two different methods for creating the second resonator,

Method 1 – Draw Freehand and Revise its Properties

1. In the same way that you created *L1*, draw a box freehand.

The *Properties* dialog box appears.

- a. Rename the object as **L2**.
 - b. Select **Material Appearance**.
 - c. Click **OK**.
2. On the **Command** tab, edit the *L2* property fields as shown in the following figure:

	Name	Value	Unit	Evaluated Value
	Command	CreateBox		
	Coordinate Sys...	Global		
	Position	-1 , -0.75 , -0.03	in	-1in , -0.75in , -0.03in
	XSize	1.818	in	1.818in
	YSize	0.125	in	0.125in
	ZSize	0.06	in	0.06in

Figure 3-17: Resonator L2 Properties – Command Tab

3. Click **OK**.

Method 2 – Copy L1 and Revise the New Object's Properties:

1. Under *Model > Solids > aluminum* in the History Tree, right-click **L1** and choose **Edit > Copy** from the shortcut menu.
2. Right-click in the Modeler window and click **Edit > Paste**. Object **L2** appears in the History Tree, but it is not in the correct location in the model.

Note:

(The advantages of this method are that the name *L1* is automatically incremented to *L2* for the new object, the *YSize* and *ZSize* dimensions of the new box are already correct, and the *Material Appearance* option is already selected.)

When you create a primitive by copying and pasting an existing object, the *Properties* dialog box does not appear automatically. Therefore, you will change the settings in the docked *Properties* window.

3. In the **Command** tab of the docked *Properties* window, edit the *L2* property fields as shown in the following figure:

Name	Value	Unit	Evaluated Value
Command	CreateBox		
Coordinate Sys...	Global		
Position	-1, -0.75, -0.03	in	-1in, -0.75in, -0.03in
XSize	1.818	in	1.818in
YSize	0.125	in	0.125in
ZSize	0.06	in	0.06in

Figure 3-18: Resonator L2 Properties – Command Tab

4. Click **OK**.

Regardless of the method you use, the model should now look like the following figure:

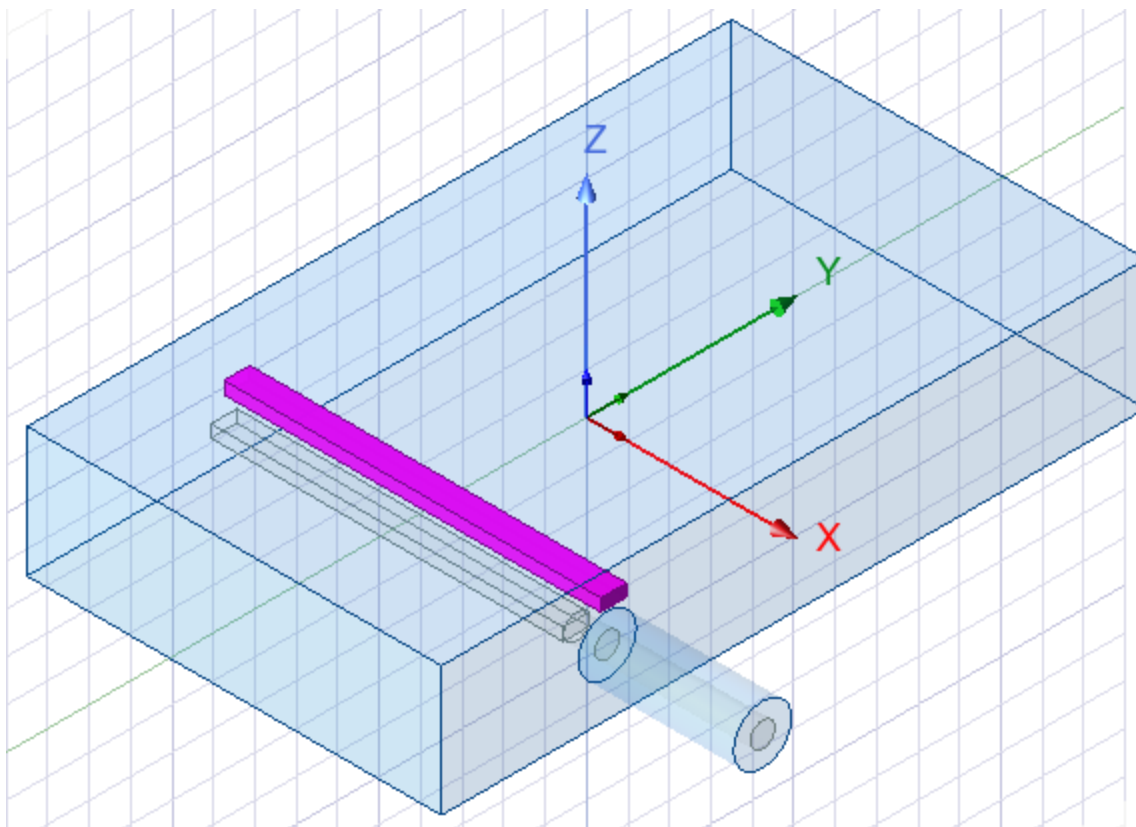

Figure 3-19: The Second Resonator (L2) Created

Create L3

1. Using your preferred method (1 or 2), as described in the [Create L2](#) page, create the third resonator (L3).

Tip:

L2 is the more efficient source for copying to L3, since L2 has the most similar dimensions and coordinates compared to L3. Beware though that some values have the same magnitudes but different signs.

2. If you drew the box freehand, specify the following settings in the **Attribute** tab of the *Properties* dialog box:
 - a. Rename the object as **L3**.
 - b. Select **Material Appearance**.

Keep the *Properties* dialog box open.

3. In the **Command** tab of either the *Properties* dialog box or the docked *Properties* window (depending on your drawing method), edit the position and sizes as shown in the following figure:

	Name	Value	Unit	Evaluated Value
	Command	CreateBox		
	Coordinate Sys...	Global		
	Position	1 ,-.048 ,-.003	in	1in , -.048in , -.003in
	XSize	-1.818	in	-1.818in
	YSize	0.125	in	0.125in
	ZSize	0.06	in	0.06in

Figure 3-20: Resonator L3 Properties – Command Tab

4. If you drew the box freehand:

Click **OK** to close the *Properties* dialog box.

Regardless of your drawing method, the model should now look like the following figure:

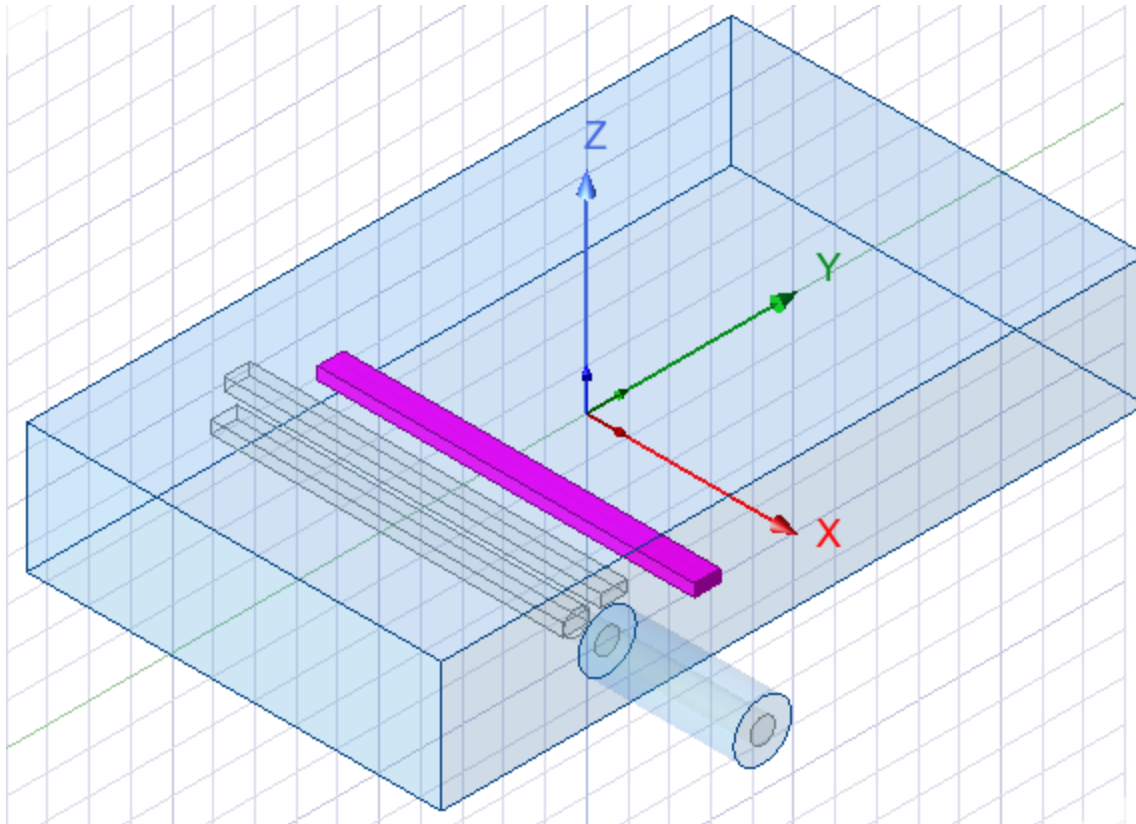

Figure 3-21: The Third Resonator (L3) Created

Create L4

1. Using your preferred method (1 or 2), as described in the [Create L2](#) page, create the fourth resonator (L4).

Tip:

L2 is the more efficient source for copying to L4, since L2 has the most similar dimensions and coordinates compared to L4.

2. If you drew the box freehand, specify the following settings in the **Attribute** tab of the *Properties* dialog box:
 - a. Rename the object as **L4**.
 - b. Select **Material Appearance**.Keep the *Properties* dialog box open.
3. In the **Command** tab of either the *Properties* dialog box or the docked *Properties* window (depending on your drawing method), edit the position and sizes as shown in the following figure:

Name	Value	Unit	Evaluated Value
Command	CreateBox		
Coordinate Sys...	Global		
Position	-1,-0.2,-0.03	in	-1in,-0.2in,-0.03in
XSize	1.818	in	1.818in
YSize	0.125	in	0.125in
ZSize	0.06	in	0.06in

Figure 3-22: Resonator L4 Properties – Command Tab

4. If you drew the box freehand:

Click **OK** to close the *Properties* dialog box.

Regardless of your drawing method, the model should now look like the following figure:

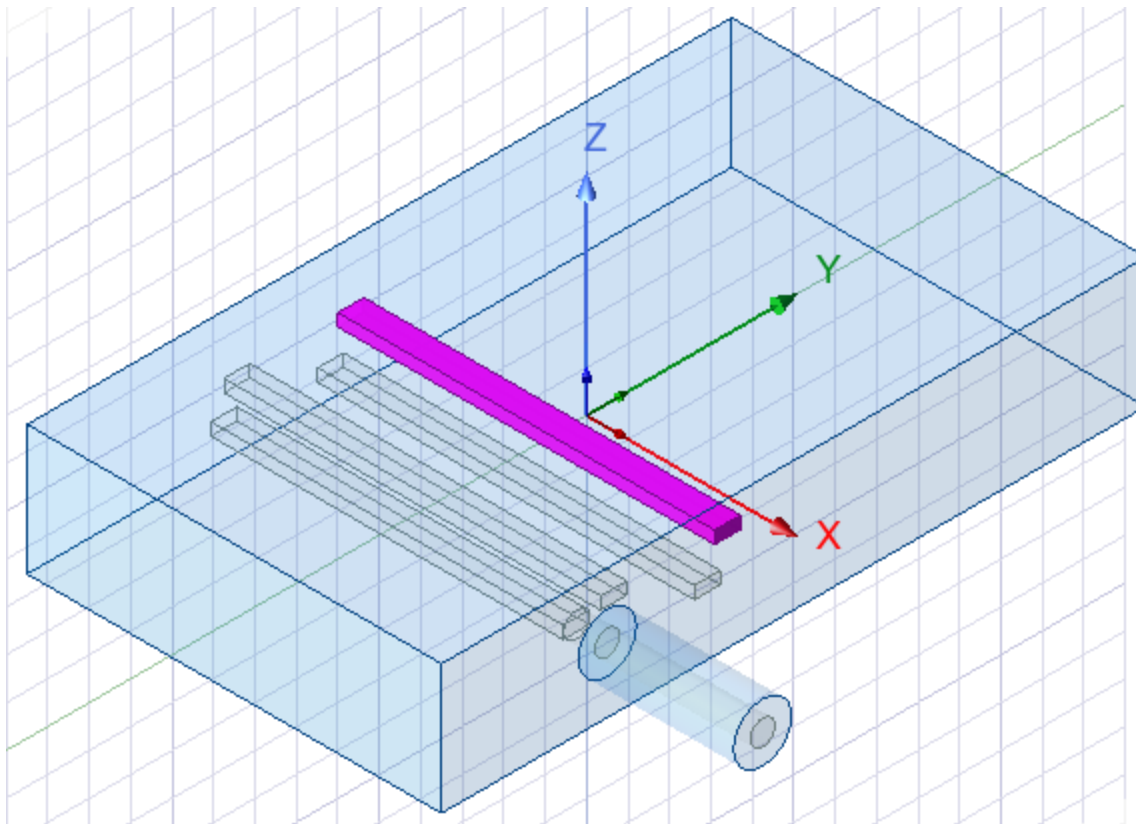

Figure 3-23: The Fourth Resonator (L4) Created

Assign Excitation

Use wave ports to excite the outer face of the coax connector as described below.

1. To enter face selection mode, press the hotkey **F** on your keyboard.
2. Select the outer face of the coax line as shown below.

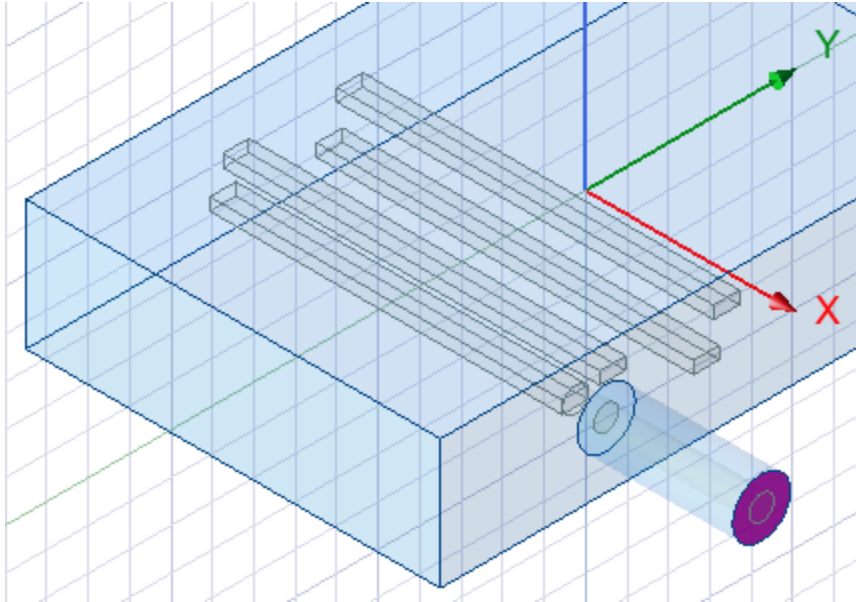

Figure 3-24: Face Selected to Assign Wave Port

3. With the face selected, right click and go to **Assign Excitation > Port > Terminal Wave Port** in the short-cut menu.

The *Reference Conductors for Terminals* dialog box appears.

4. Enter the port name (**P1**) and select the option **Use port object name**, as shown in the following image. Then, click **OK**.

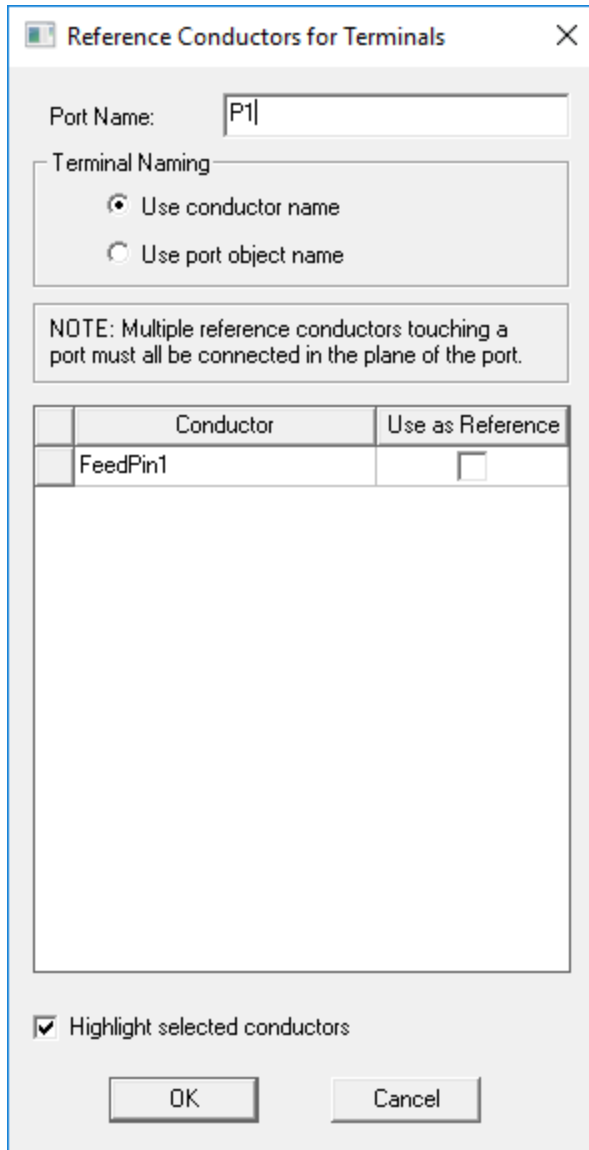

Figure 3-25: Reference Conductors for Terminals

The wave port and feed terminal are assigned, and both items appear in the Project Manager under *Excitations*.

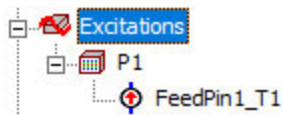

Figure 3-26: Project Manager – Excitations Branch

5. Select **FeedPin1_T1** in the Project Manager and press **F2** to rename the terminal. Make the new name **T1** and press **Enter**.

Note:

Simplifying the name of the terminal will make the selection of the parameters to plot easier and the plot legend text shorter.

6. Select **P1** or **T1** in the Project Manager to see the port or terminal visualization, respectively:

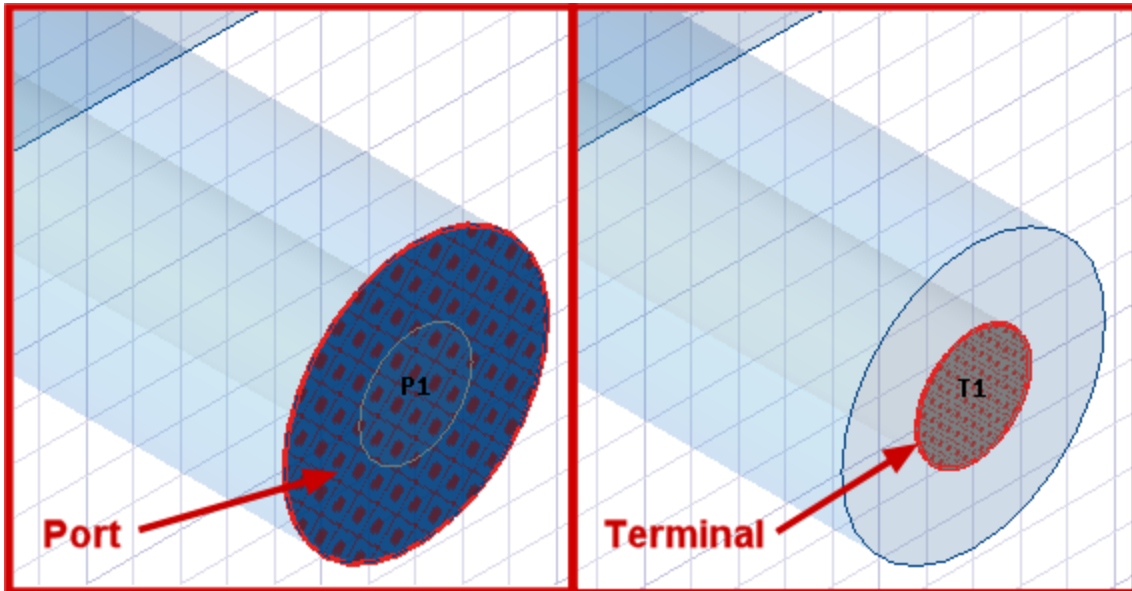

Figure 3-27: Close-up View of Port and Terminal Assignments

Create Remaining Objects by Duplication

You are almost through drawing the model. The only remaining task is to create the remaining objects by duplicating the vacuum object *Feed1* and all the aluminum conductors that you have drawn. The wave port excitation will also be duplicated along with the feed objects. The steps are as follows:

1. To enter object selection mode, press the hotkey **O** on your keyboard.

Note:

Alternatively, choose **Object** from the **Select** drop-down menu on the **Draw** ribbon tab.

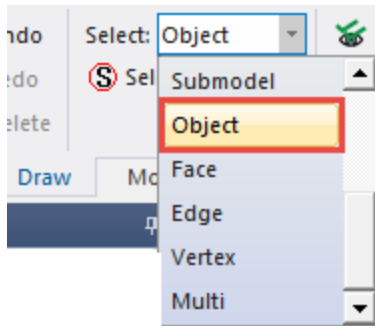

2. Click **Select by Name** on the **Draw** tab.

The *Select Object* dialog box appears.

3. Select the following objects and click **OK**:

Feed1, FeedPin1, FeedProbe1, L1, L2, L3, and L4.

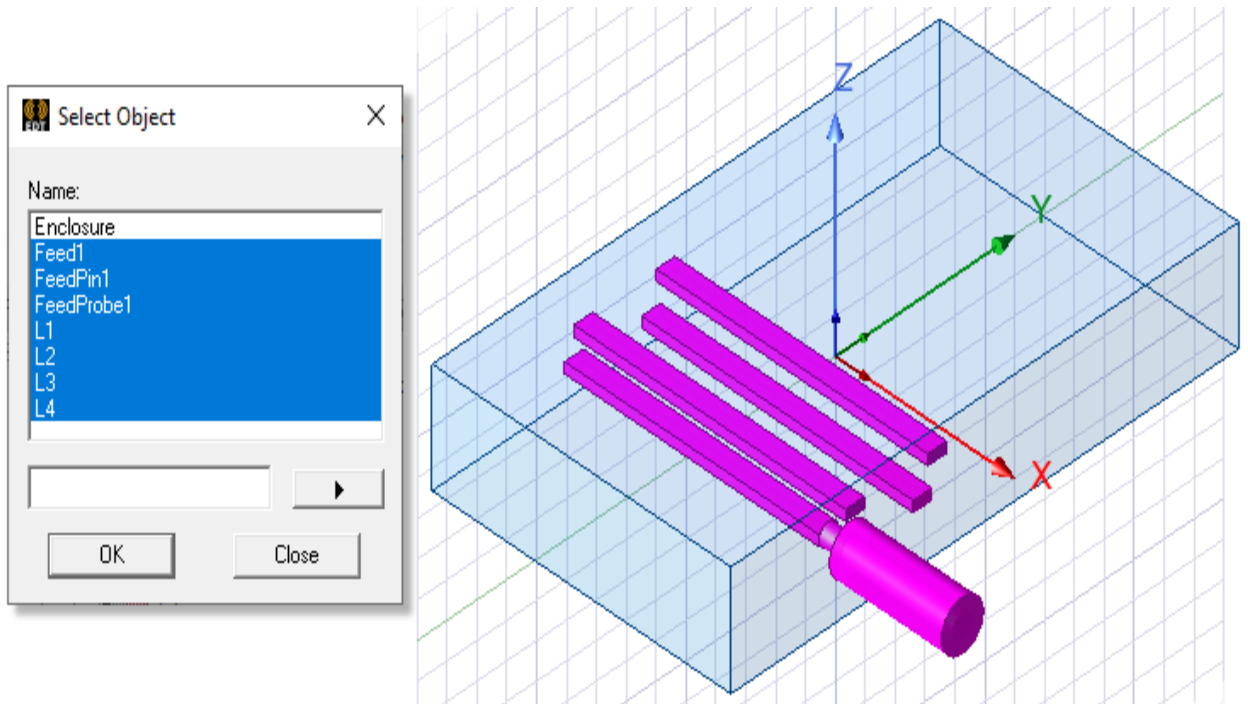

Figure 3-28: Select Object Dialog Box

4. With the objects selected, right-click and select **Edit > Duplicate > Around Axis** from the short-cut menu.

The *Duplicate Around Axis* dialog box appears.

5. Select **Z** as the **Axis**, specify as **180 deg** for the **Angle**, and **2** as the **Total number**, as shown in the following figure. Then, click **OK**.

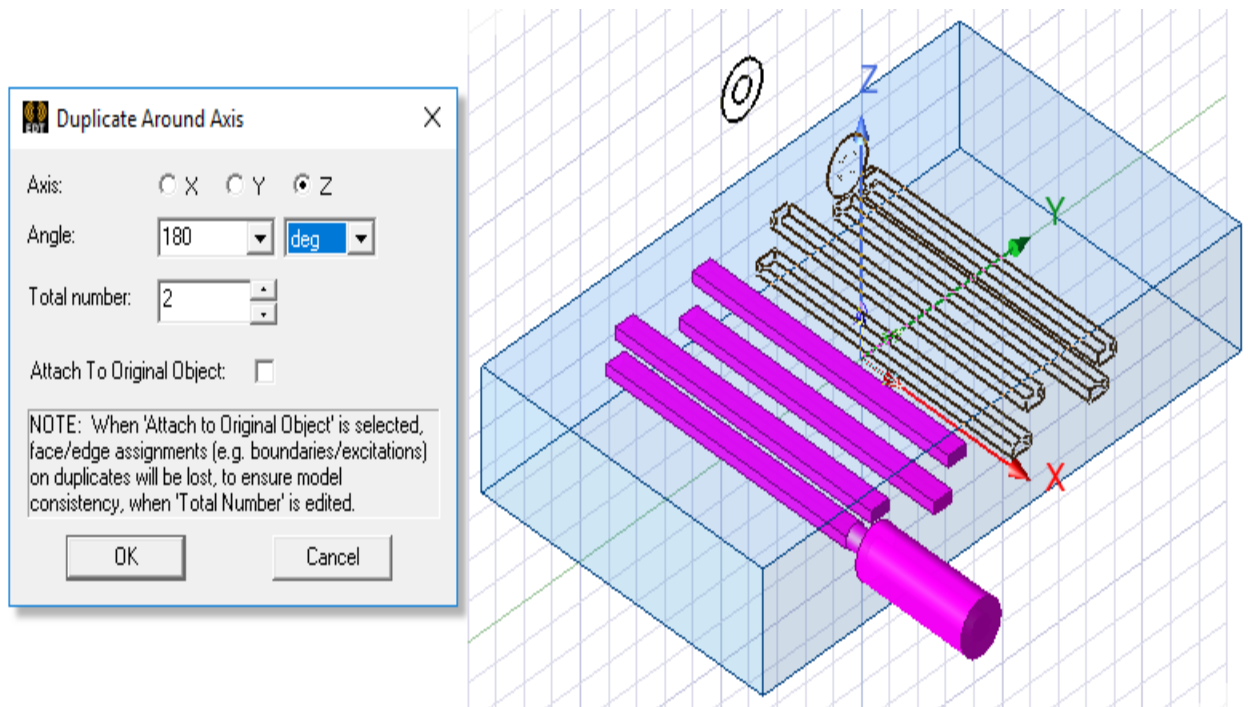



Figure 3-29: Duplicate Around Axis Z

6. Click **OK** to close the *Properties* dialog box that appears.
7. Click in the Modeler window background area to clear the current selection.
8. Now that construction of the model is complete, click  **Grid** on the **Draw** ribbon tab to toggle off the grid visibility.

The bandpass filter model should now look like the following figure. Observe that the ports and terminals are duplicated along with the geometry, and the *Excitations* branch of the Project Manager is updated. The wave port and terminal names are automatically incremented to *P2* and *T2*, respectively.

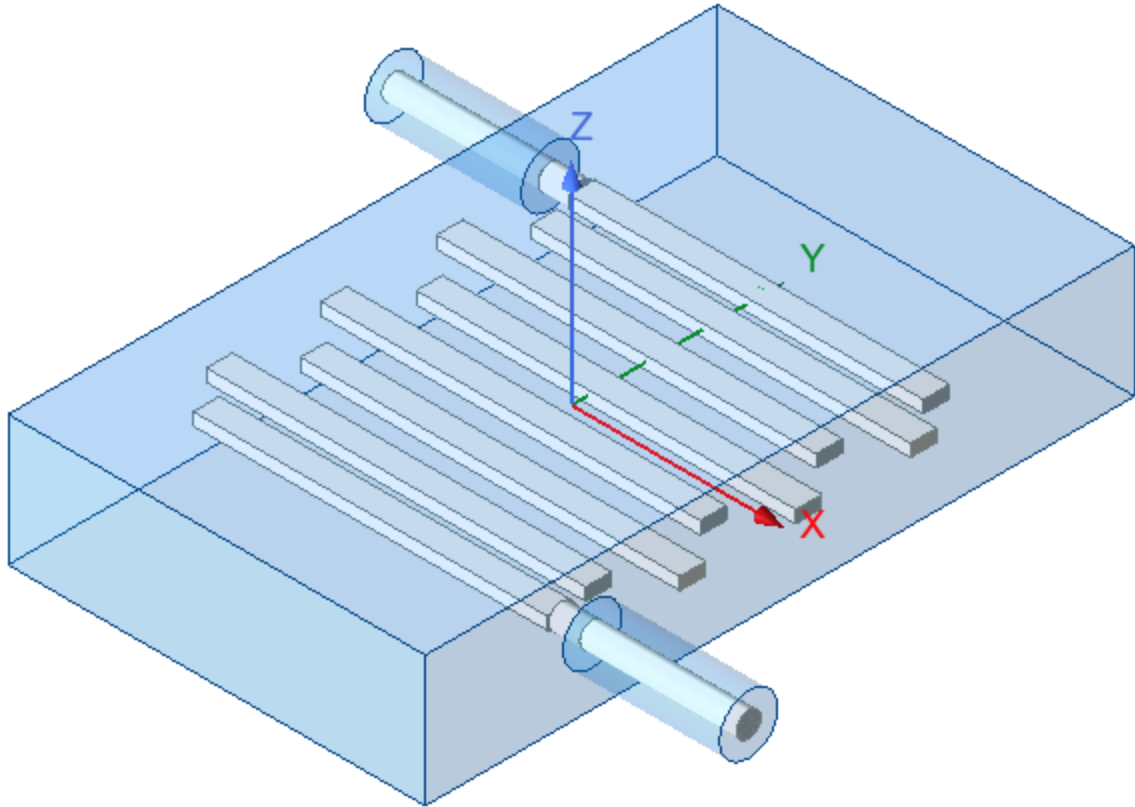

Figure 3-30: Duplication of the Parts

Boundary Display (Optional)

Boundary display/solver view provides a snapshot of all boundaries in the model including ports and surface residing on the surrounding background object. It can be very useful for diagnosing problems with design setups.

1. On the menu bar click **HFSS > Boundary Display (Solver View)**.

The *Solver View of Boundaries* dialog box appears.

HFSS identifies all the unique boundary conditions and ports to display where the boundaries are physically located in the model.

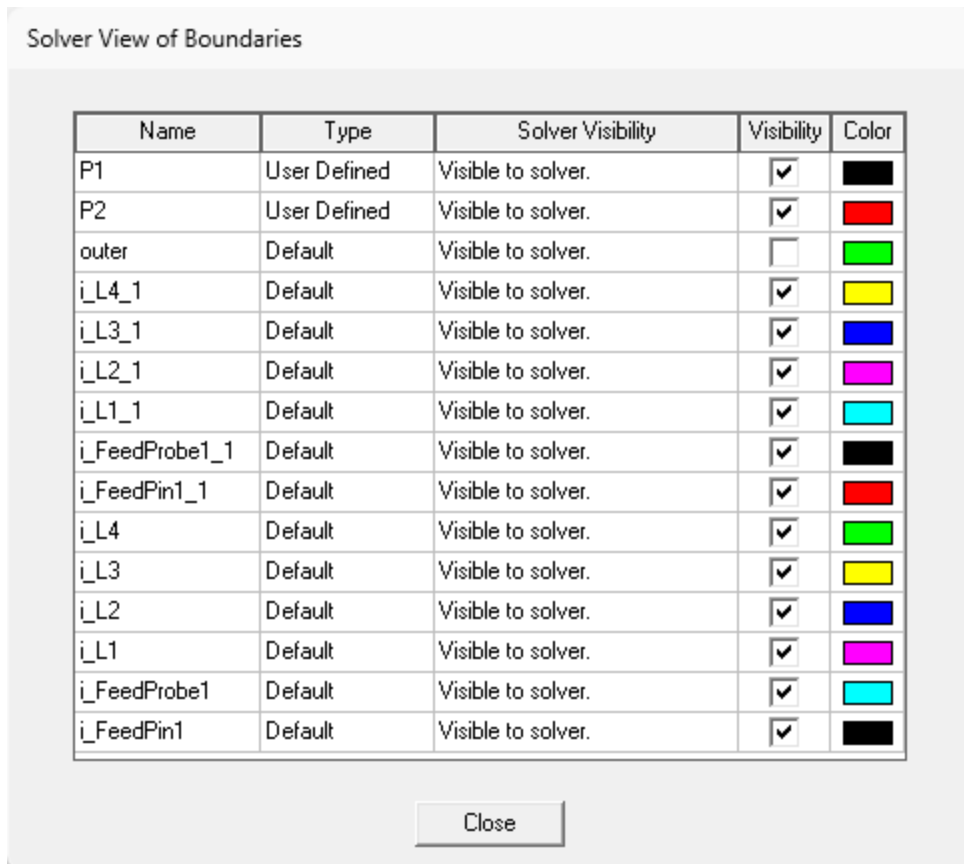

Figure 3-31: Solver View of Boundaries Dialog Box

- Click the **Visibility** check box for the boundaries you wish to display. To toggle the visibility of all boundaries in a single operation, click the **Visibility** heading.

Note:

The two ports and the conductors are listed individually by name. The *Enclosure* is displayed as the *outer* boundary. If you want, you can change any color from the palette that appears when you double-click a cell in the **Color** column.

In the following figure, *Visibility* is enabled for all the aluminum parts and for *Feed1* and *Feed1_1*. Only the *outer* boundary is excluded:

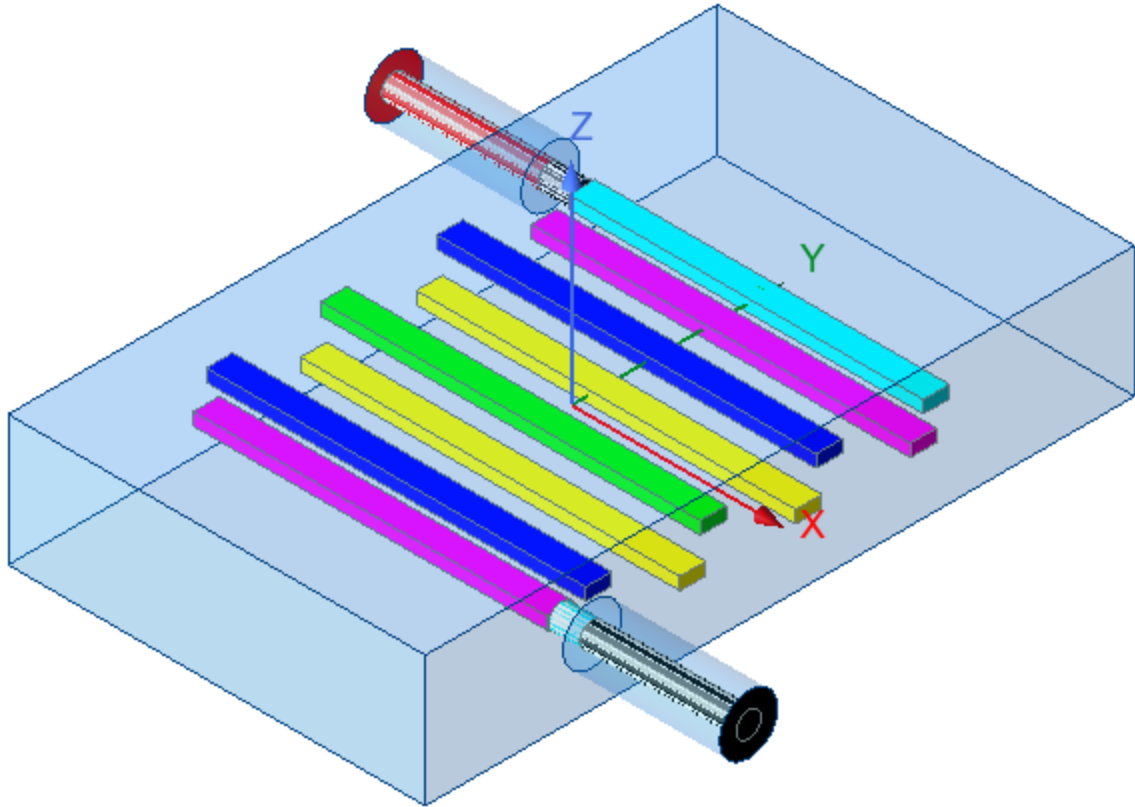

Figure 3-32: Boundaries Displayed

3. On the *Solver View of Boundaries* dialog box, click **Close**.

On the **View** ribbon tab, click  **Hide/Show overlaid visualization in the active view** option.

The *Active View Visibility* dialog box appears.

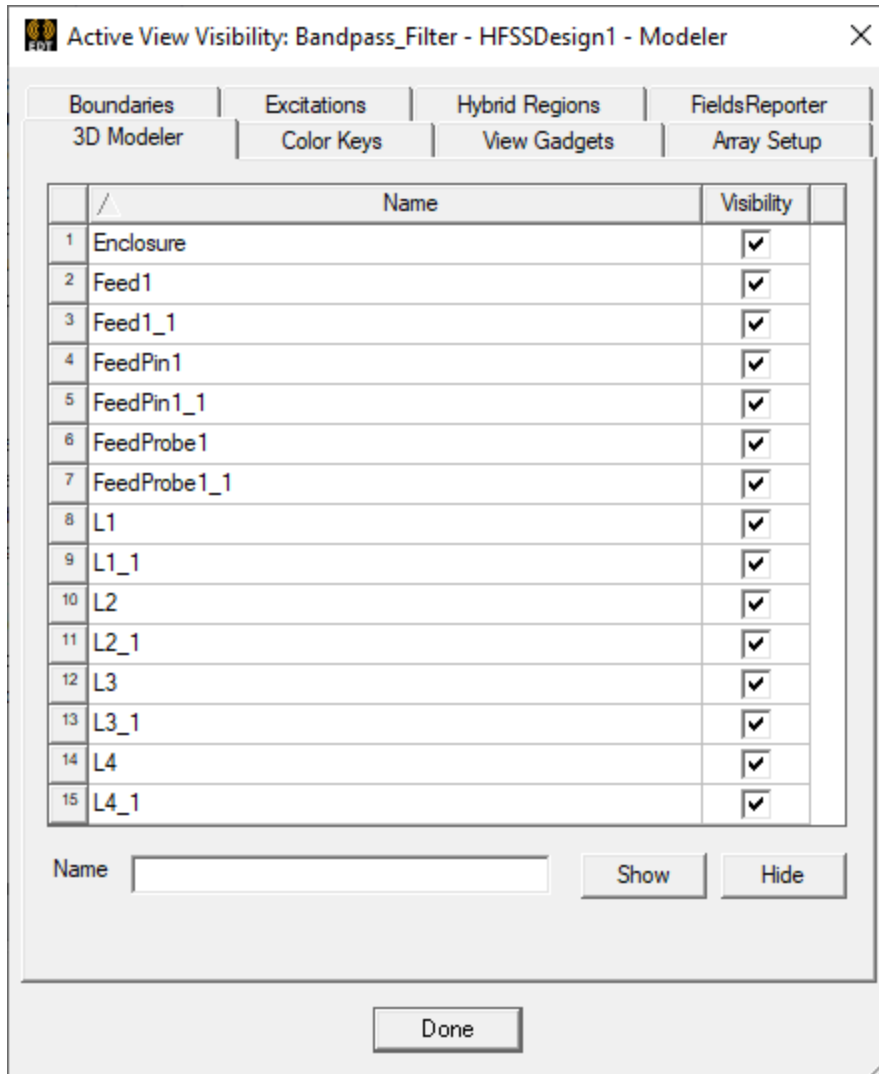

Figure 3-33: Active View Visibility Dialog Box

- In the **3D Modeler** tab, deselect **Visibility** for any objects that you don't want to see.

Note:

You can use wildcards (* or ?) in the **Name** field to quickly show or hide multiple objects. For example, you could use the name *L?_1* to show or hide all the duplicate resonator parts in a single operation. In the **Excitations** tab, you can also show or hide excitations that you've applied to the model.

- On the *Active View Visibility* dialog box, verify that **Visibility** is checked for all the objects under the **3D Modeler** tab and click **Done**.

4 - Set Up and Analyze the Model

This chapter includes the following sections and subsections:

- Add Solution Setup and Frequency Sweep
- Add HPC Analysis Setup
- Validate and Analyze the Bandpass Filter
- Review Solution Data
 - Review Profile Panel
 - Review Convergence Panel
 - Review Matrix Data Panel
 - Review Mesh Statistics Panel

Add Solution Setup and Frequency Sweep

1. On the **Simulation** ribbon tab, click **Setup > Advanced**:

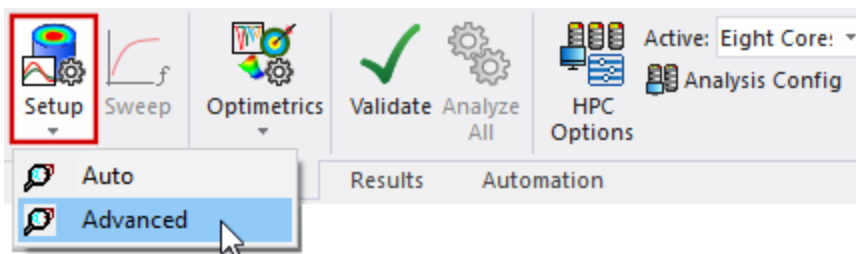

The *Driven Solution Setup* dialog box appears.

2. Edit the fields on the **General** tab, as shown in the following figure. Note that a "p" is used in the *Setup Name* because decimal points are not permitted here (*1p5GHz* represents the 1.5 GHz adaptive solution frequency):

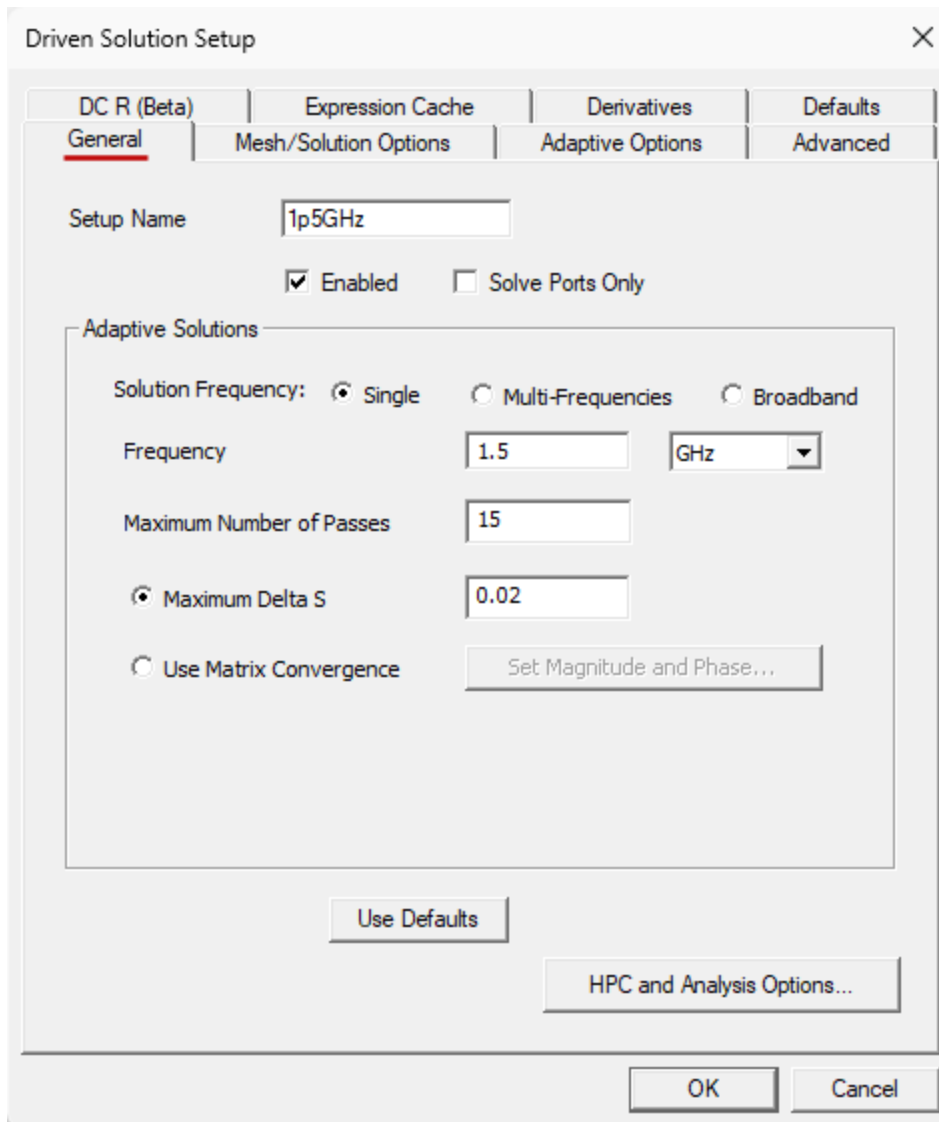

Figure 4-1: Driven Solution Setup Dialog Box – General Tab

Note:

This dialog box defines how HFSS automatically generates an accurate mesh and helps you define the stopping criteria for the mesh adaptation process.

3. On the **Mesh/Solution Options** tab, ensure that **Auto Select Direct/Iterative** is selected:

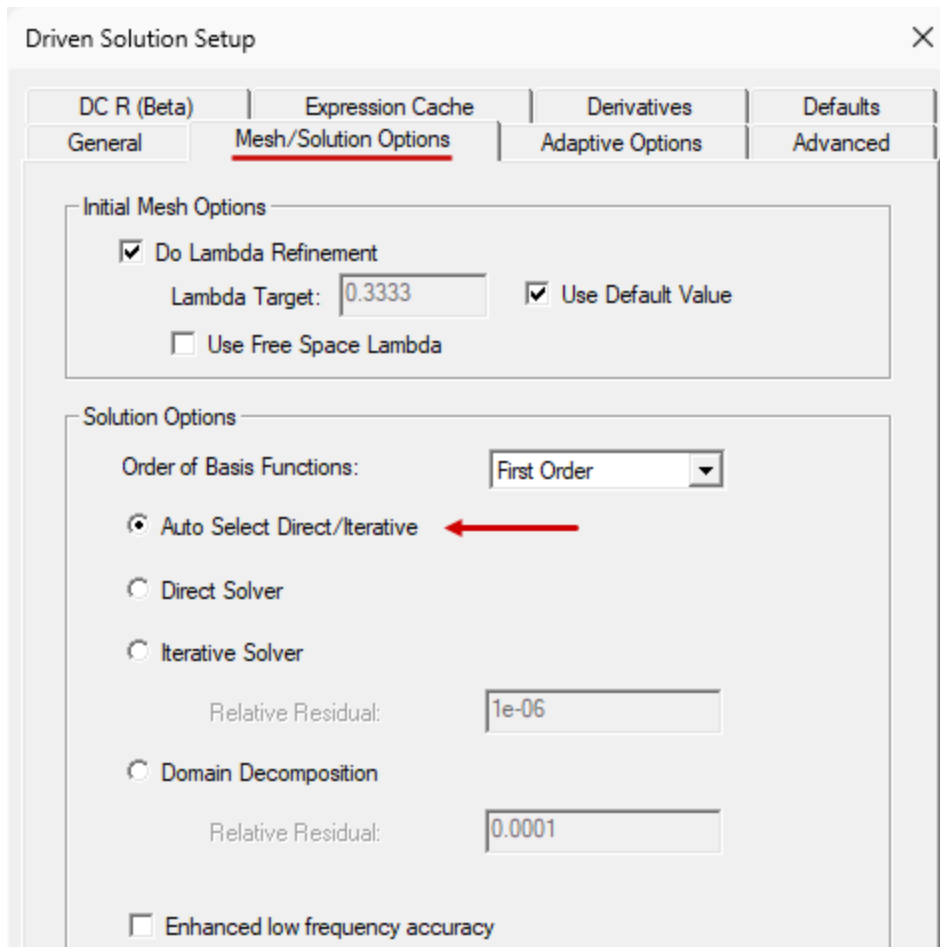

Figure 4-2: Driven Solution Setup Dialog Box – Mesh/Solution Options Tab

4. Click **OK**.

For models that include any type of assigned port excitation, upon completing the addition of an advanced solution setup, the *Edit Frequency Sweep* dialog box appears automatically.

5. Edit the fields as shown in the following figure. Then, click **OK**.

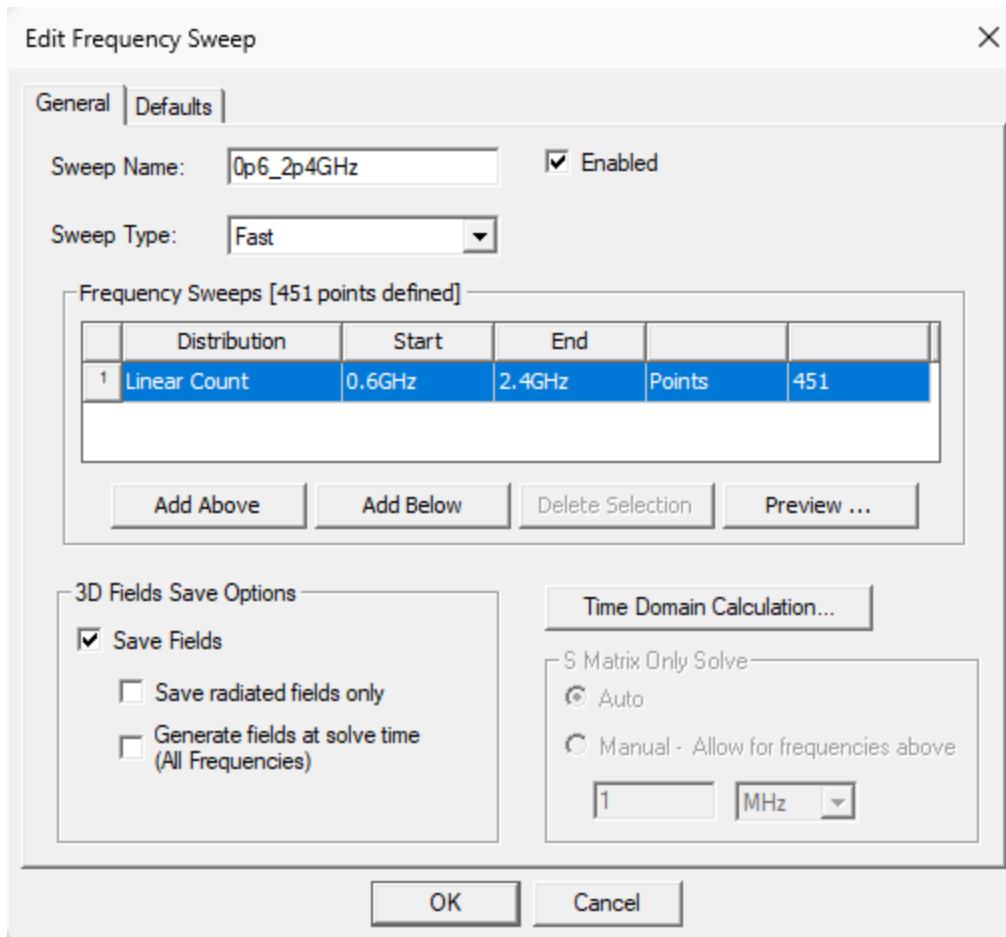

Figure 4-3: Edit Frequency Sweep Dialog Box

Analysis setup (1p5GHz) and its frequency sweep (0p6_2p4GHz) are listed under *Analysis* in the Project Manager.

6.  **Save** the Project.

Add HPC Analysis Setup

HFSS provides the **HPC and Analysis Options** setup for the purpose of **High Performance Computing**, which ensures efficient simulation. Since you are solving a frequency sweep in this design, using HPC distributes the frequencies across available cores, making optimum use of the computer resources.

Note:

Ignore this section if you do not want to use HPC.

1. Go to the **Simulation** ribbon tab and select **HPC Options**, as shown in the following figure.

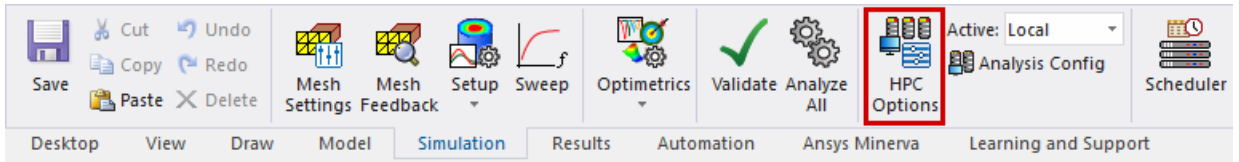

Figure 4-4: Access HPC and Analysis Options

The *HPC and Analysis Options* dialog box appears.

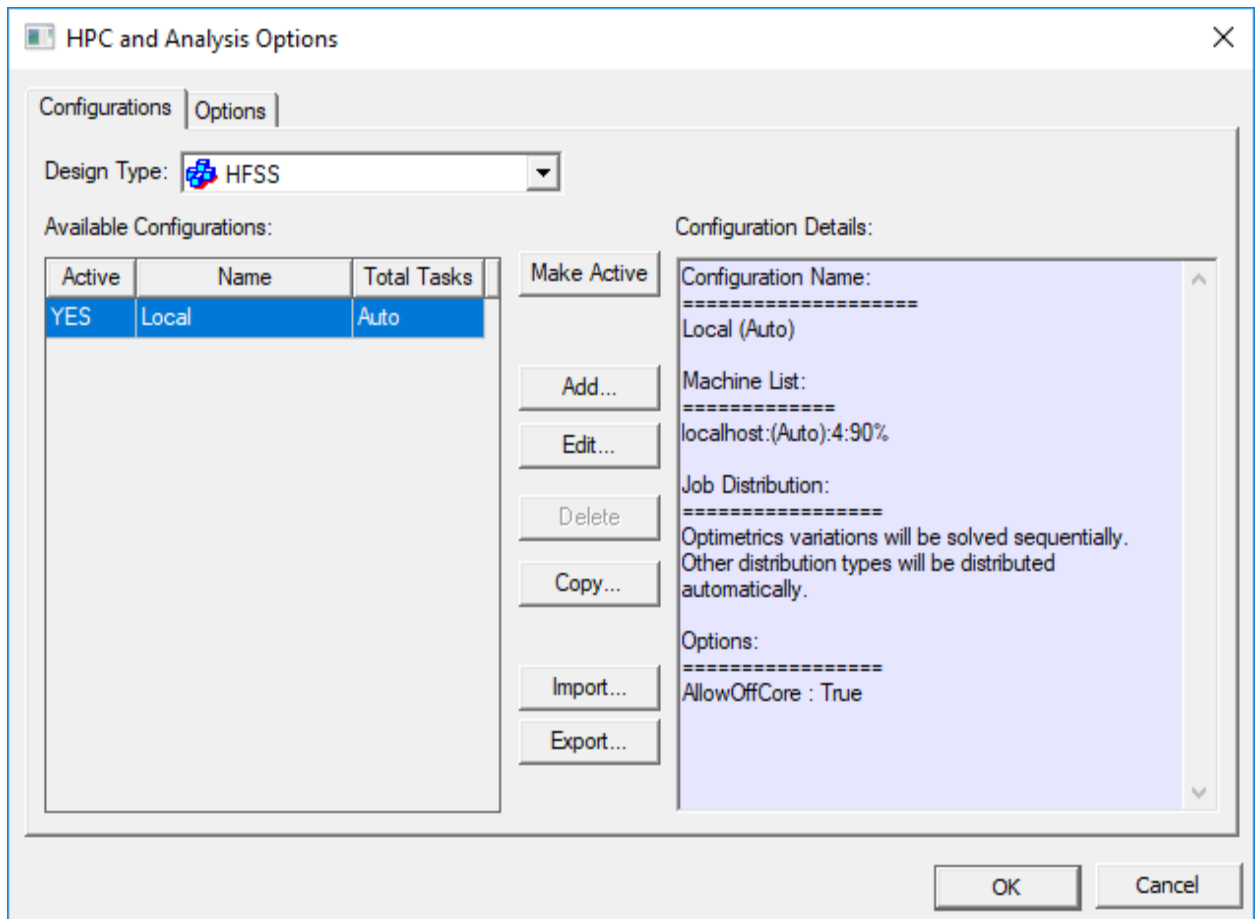

Figure 4-5: HPC and Analysis Options Dialog Box

2. Select the **Design Type** for which you want to set up HPC from the drop-down menu, if the correct type is not already selected.

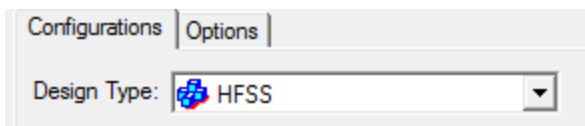
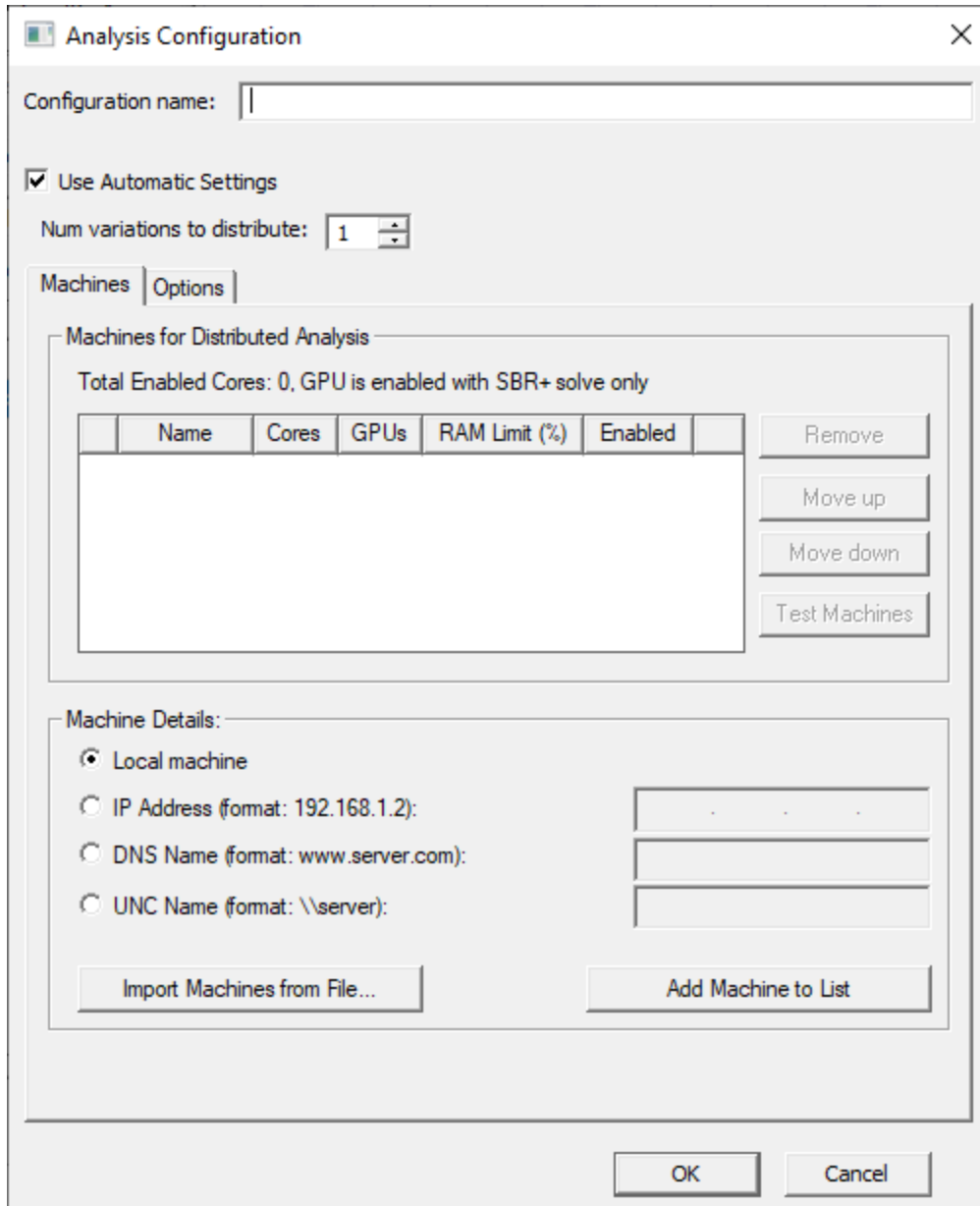

Figure 4-6: Design Type for HPC and Analysis Options

3. Click the **Add** button.

The *Analysis Configuration* dialog box appears, as shown in the following figure:

**Figure 4-7: Analysis Configuration Dialog Box**

4. Enter a name in the **Configuration name** text box.

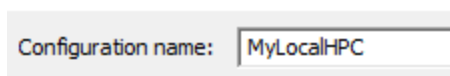
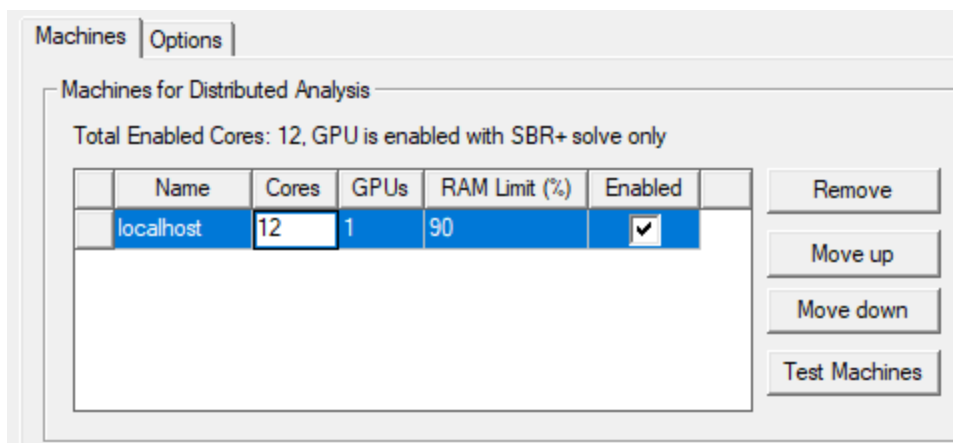

Figure 4-8: Set the Configuration Name

5. Select **Use Automatic Settings**.

Based on the best use of available resources for the current analysis, this setting automatically selects the number of parallel tasks.

6. In the *Machine Details* panel, select **Local Machine** and click **Add Machine to List**.
7. Set the total number of **Cores** to be no greater than the number of physical processor cores included in your computer. You may choose to allocate fewer than the number of available cores to reserve some resources for concurrently running applications. The following image shows the appropriate setting for maximum simulation resources on a 12-core PC:

**Figure 4-9: Number of Cores****Note:**

- You will achieve the best performance if hyperthreading is *disabled* in your system BIOS. For computationally intensive applications, such as finite element analysis, it is best to give one or more full physical cores to each task. Hyperthreading causes two or more tasks to be assigned to a single physical processor core, dividing the core between the threads.
- The number of tasks is based on a factor associated with the total cores. On a machine with 12 available cores, when the number of tasks is 4, optimum use of the available cores happens (3 cores per task x 4 tasks = 12 cores). However, if the number of tasks is 5, 2 of the available 12 cores remain idle (2 cores per task x 5 tasks = 10 cores).

8. Leave the **Num variations to distribute** setting and the default settings in the **Options** tab as they are and click **OK**.

In the *HPC and Analysis Options* dialog box, the *Available Configurations* and *Configuration Details* panels have been updated with the configuration you just created.

- Select the row that was just added to the **Available Configurations** list. Identify it by the name you specified in step 4. Then, click **Make Active** if this configuration is not already the active one. The dialog box should now look like the following image:

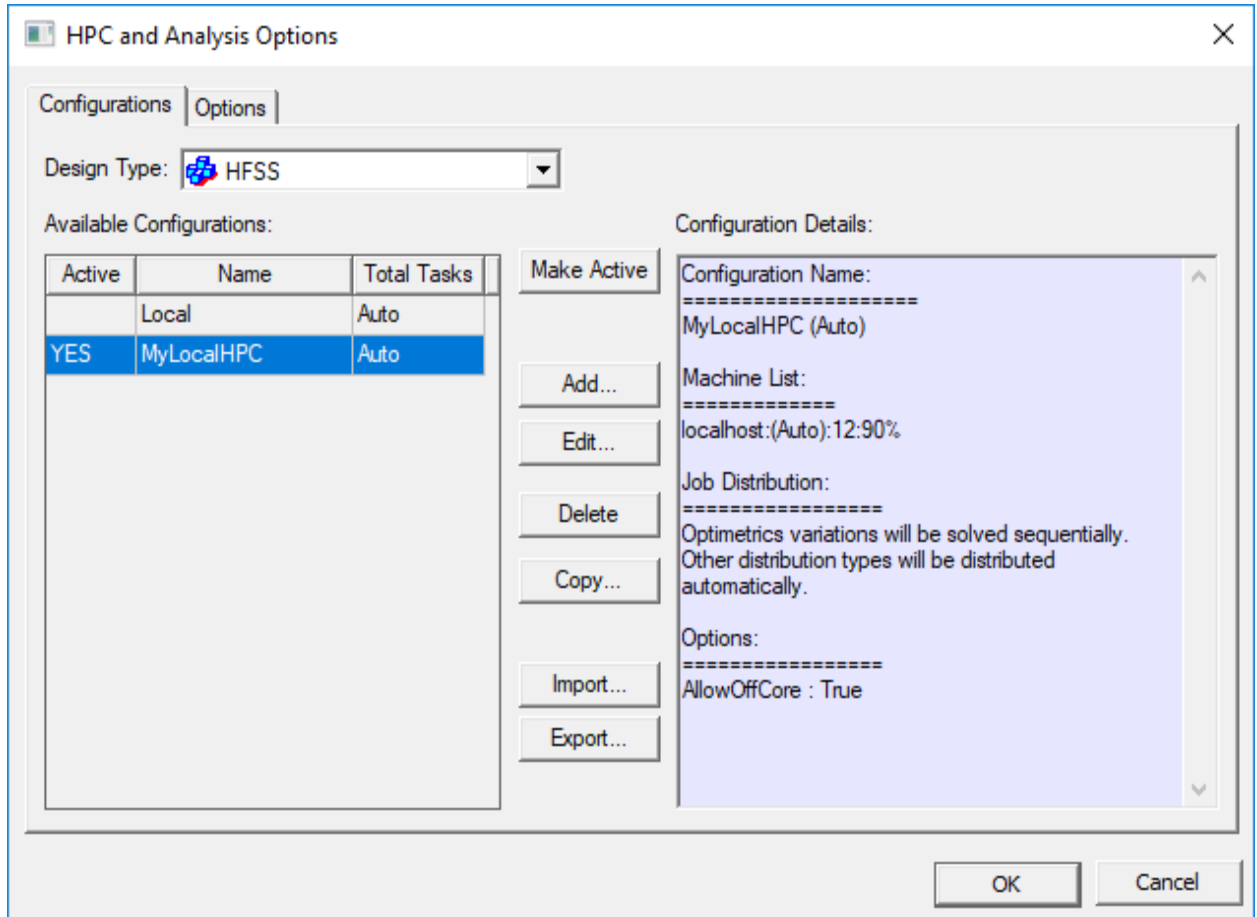

- Click **OK** to complete the HPC configuration and close the dialog box.

What HFSS Does with the HPC Configuration

HFSS intelligently determines which jobs are to be performed and how to distribute them for the simulation. It automatically apportions the jobs during the simulation process and makes optimum use of the available resources.

For this HPC configuration, first HFSS uses 12 cores of matrix multiprocessing for the adaptive mesh generation. The number of cores used for solving each frequency point is determined by Total Cores/Number of Tasks. So, after adaptive mesh generation HFSS uses the same 12 cores during the frequency sweep by running 4 frequency points in parallel with 3 cores matrix-multiprocessing per frequency point. This solves faster since running frequency points in parallel ensures a more scalable HPC technology than matrix-multiprocessing alone. However, since 4

frequency points are solved in parallel the analysis uses 4 times the memory of the last adaptive pass. So, it is assumed that the machine has adequate memory to solve the 4 frequency points. As an alternative you can use HPC to leverage cores on networked physical nodes, which can provide the additional memory for the parallel frequency points.

Of course, for your PC and HPC configuration, the number of cores and the resultant computing scheme may be different.

Validate and Analyze the Bandpass Filter

The model has to pass the validation check to confirm your design is set up correctly before you analyze it.

1. Click **Validate** on the **Simulation** ribbon tab.

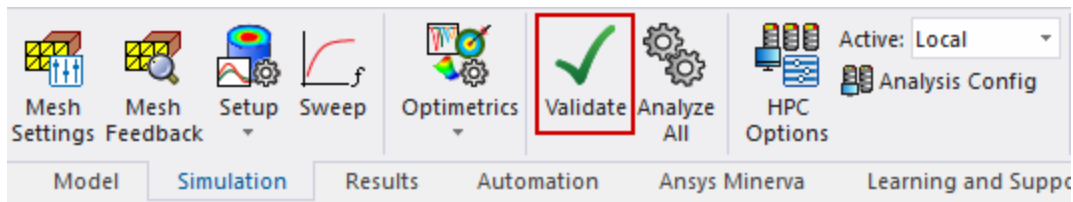

The *Validation Check* dialog box appears.

Note:

In HFSS projects, warnings might appear in the *Message Manager* window. Some of these messages are informational, warning you of potential problems. The messages may not always require you to perform any action to deal them.

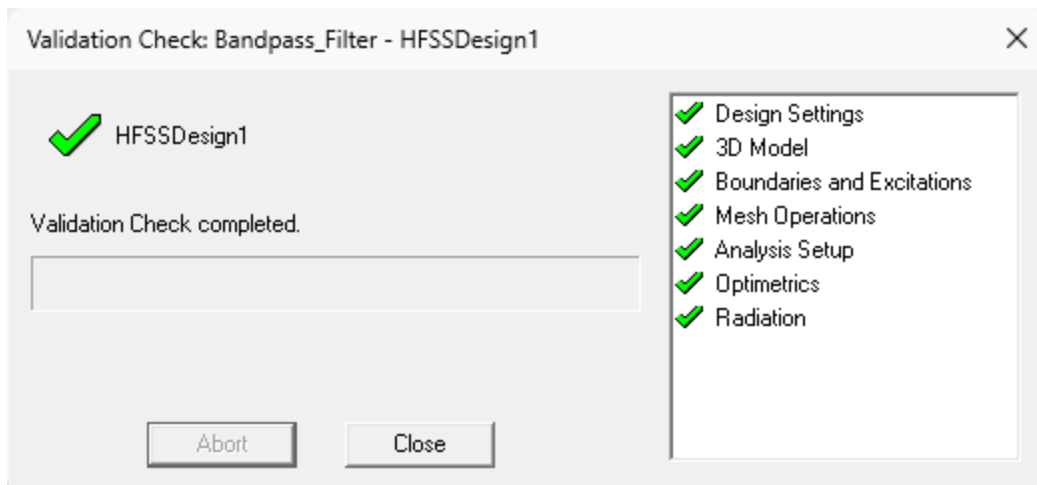
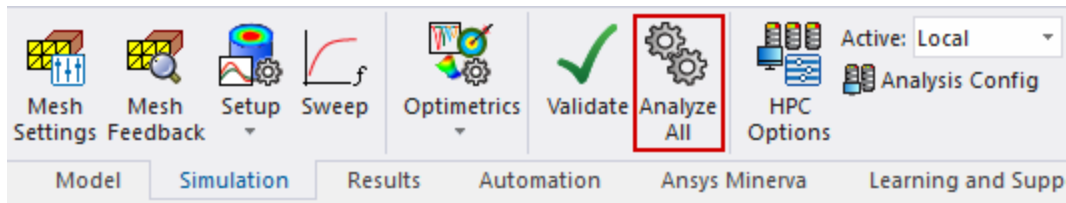

Figure 4-10: Validation Check Dialog Box.

2. If your validation check looks like the preceding figure, click **Close**. Otherwise, recheck your work up to this point.
3. Click **Analyze All** on the **Simulation** ribbon tab.



Review Solution Data

1. On the **Results** ribbon tab, click **Solution Data**.

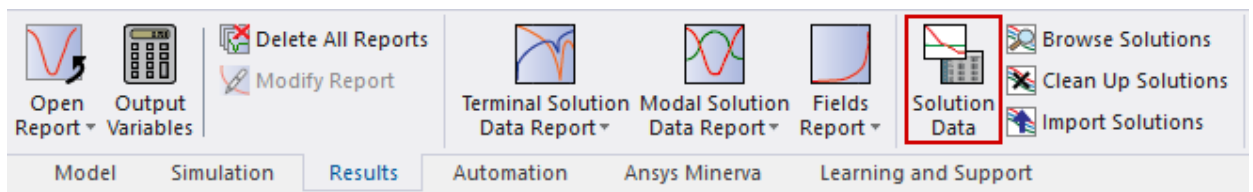

The *Solutions* dialog box appears.

Note:

The subsections that follow describe all of the panels that constitute the *Solutions* dialog box. You can review solution data while analysis is being solved.

Solving Time

Depending on your computer hardware and HPC configuration, solving time can vary considerably. On a 16-core, 2.5 GHz, Intel i7 processor-based PC with 64 GB RAM, this solution took about 1.2 minutes to finish.

Review the Profile Panel

1. On the *Solutions* dialog box click the **Profile** tab.

The Profile window provides a synopsis of the different stages of the solution process for the extraction of electromagnetic field and S, Y, and Z parameter data. The following figure shows the results ranging from mesh generation, the last adaptive pass, the matrix assembly, the beginning of the frequency sweep, and the automatic solver selection.

For the Profile window shown in the figure, HPC was enabled. The solution converged in nine passes. Your results may differ slightly. For all adaptive passes, HFSS employed HPC technology using the 16 cores specified in the HPC setup. After convergence was

achieved, solving the 451 points of the fast frequency sweep began. The *Direct Solver* was chosen by automatic selection.

Task	Real Time	CPU Time	Memory	Information
Adaptive Pass 9				Frequency: 1.5GHz
Adaptive Refine	00:00:01	00:00:01	58.6 M	Tetrahedra: 28487, Cores: 1
Simulation Setup	00:00:00	00:00:00	232 M	Tetrahedra: 26535, Disk: 10.2 KB
Matrix Assembly	00:00:02	00:00:07	477 M	Tetrahedra: 26535, P1 Triangles: 104, P2 Triangles: 104, Disk: 0 Bytes Matrix solver automatically selects Iterative Solver
Matrix Solve	00:00:01	00:00:19	618 M	Type: DCS-L2, Cores: 16, Matrix size: 168444, Matrix bandwidth: 21.3, Iterations: 14.5,
Field Recovery	00:00:00	00:00:05	618 M	Excitations: 2, Disk: 1.1 MB
Data Transfer	00:00:00	00:00:00	99.9 M	Adaptive Pass 9 Max Mag. Delta S: 0.01630
Adaptive Meshing				Elapsed Time: 00:00:54 Adaptive Passes converged
Frequency Sweep				Time: 08/07/2024 13:32:02 HPC: Enabled
Solution Op6_2p4GHz				Fast Sweep From 0.6 GHz to 2.4 GHz, 450 Steps
Simulation Setup	00:00:00	00:00:00	225 M	Disk: 0 Bytes
Matrix Assembly	00:00:05	00:00:06	465 M	Tetrahedra: 26535, P1 Triangles: 104, P2 Triangles: 104, Disk: 0 Bytes Matrix solver automatically selects Direct Solver

Figure 4-11: Profile Data Showing Final Adaptive Pass and Beginning of Sweep

2. Leave the *Solutions* dialog box open and proceed to the next topic.

Review the Convergence Panel

1. In the *Solutions* dialog box, click the **Convergence** tab.

The table showing *Convergence* data is displayed:

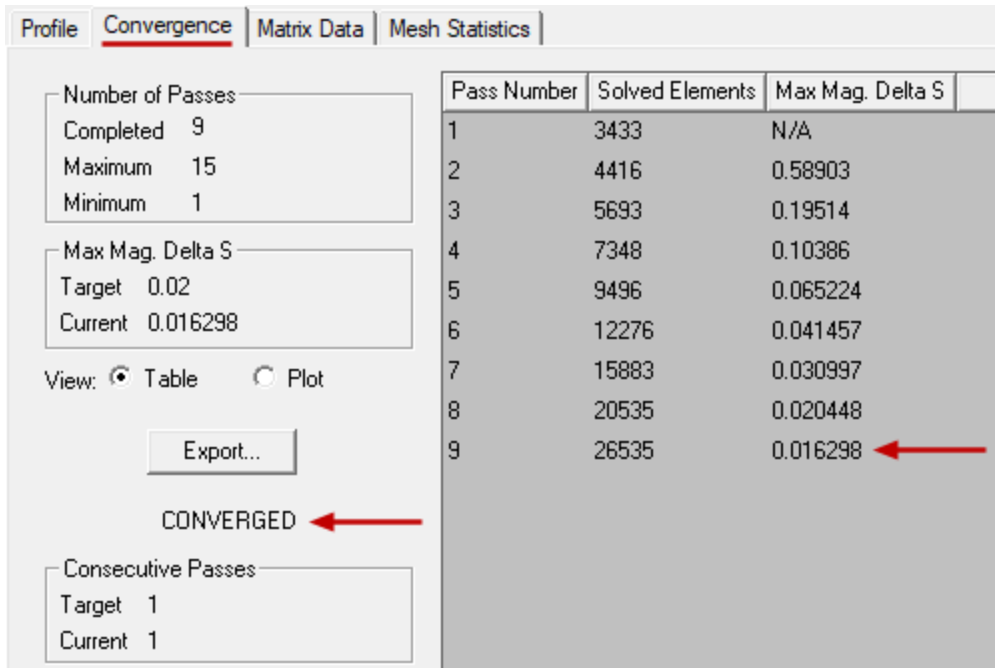

Figure 4-12: Convergence Data Table

2. Click the **Plot** option button.

A graph of the convergence data is displayed.

3. Select the **X** and **Y** axes for your plot from the drop-down menu as shown in the following figure:

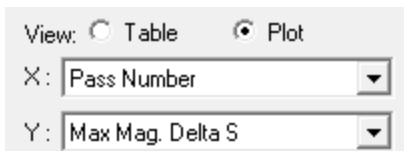

Figure 4-13: X, Y drop down menus

The plot for *Max Mag. Delta S* versus *Pass Number* appears. See figure below.

Note:

Other graphs are displayed as you change the X and Y options from the drop-down menus.

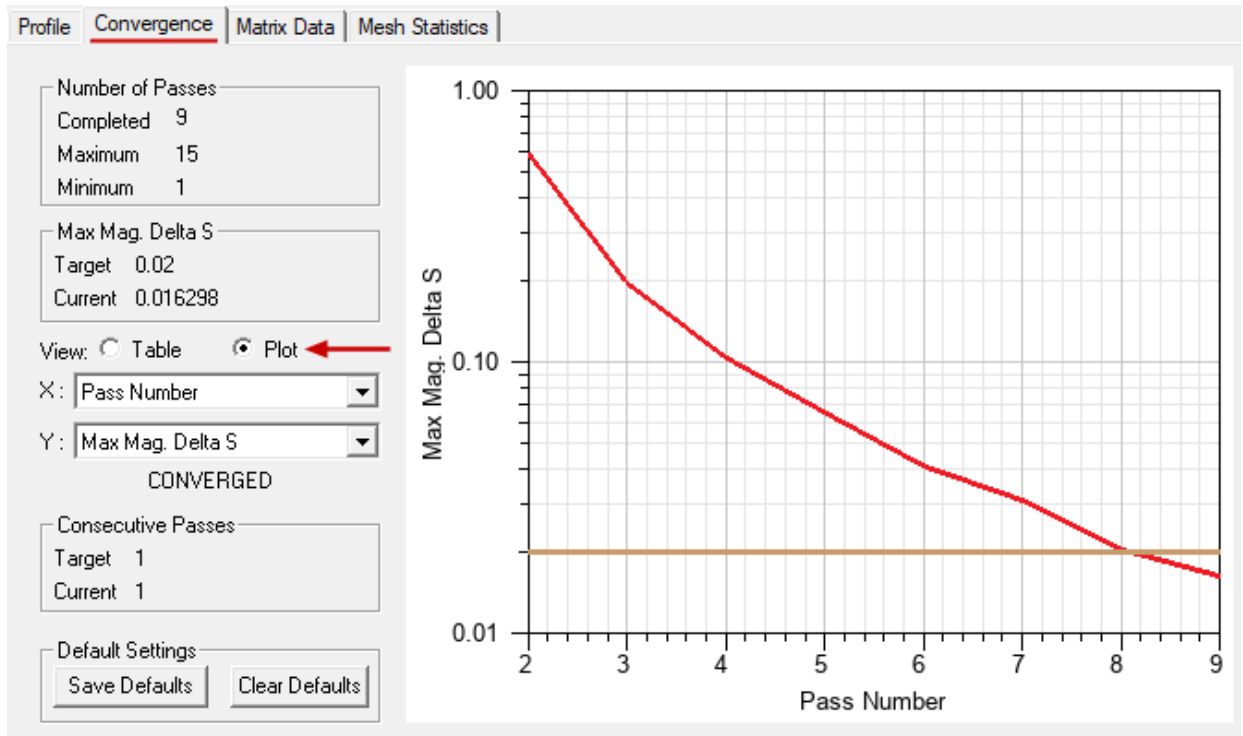

Figure 4-14: Convergence Graph

4. Leave the *Solutions* dialog box open and proceed to the next subsection.

Review Matrix Data Panel

1. Click the **Matrix Data** tab to view information about the S-parameters. For a real-time update of the Matrix Data (when the solution is still in progress), set the **Simulation** options to **Setup1** and **Last Adaptive**.

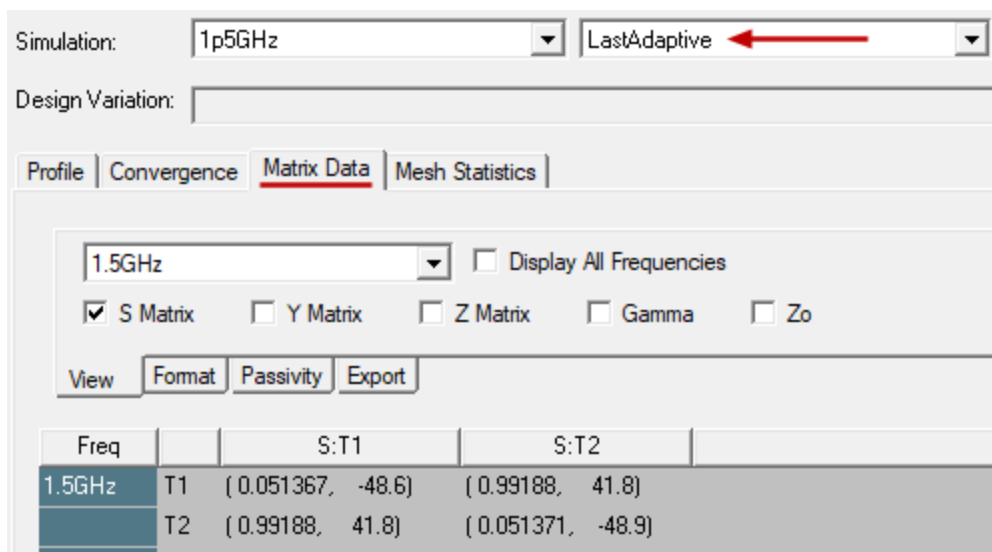

Figure 4-15: Matrix Data Panel

2. Leave the *Solutions* dialog box open and proceed to the next subsection.

Review Mesh Statistics Panel

1. Click the **Mesh Statistics** tab to see information about the tetrahedra that were generated and solved for the individual components. The total number of elements is reported too.

Profile Convergence Matrix Data Mesh Statistics								
Total number of elements: 28487 								
	Num Tets	Min edge length	Max edge length	RMS edge length	Min tet vol	Max tet vol	Mean tet vol	Std Devn (vol)
Enclosure	24672	0.0228425	1.03208	0.148416	4.49829e-07	0.0223217	0.000167776	0.00056428
Feed1	940	0.0374408	0.240096	0.128094	1.68603e-06	0.000159919	3.9099e-05	3.14857e-05
Feed1_1	923	0.0386733	0.245534	0.121633	2.5459e-06	0.000151608	3.98305e-05	3.00746e-05
FeedPin1	422	0.0468875	0.215347	0.113999	2.75598e-07	0.00021486	1.95876e-05	2.73439e-05
FeedPin1_1	408	0.0458985	0.198083	0.11354	2.75598e-07	0.000196144	2.02597e-05	2.62771e-05
FeedProbe1	101	0.0541719	0.151816	0.10626	6.32905e-07	0.000113914	1.63811e-05	2.18998e-05
FeedProbe1_1	104	0.0541719	0.151816	0.105637	6.32905e-07	0.000113914	1.59086e-05	2.1603e-05
L1	116	0.0277886	0.297123	0.169281	2.44679e-07	0.000315228	0.000109965	8.65238e-05
L1_1	121	0.0418822	0.2418	0.157384	3.86965e-07	0.00030225	0.00010541	8.17041e-05
L2	102	0.0866386	0.19776	0.154975	2.37253e-05	0.000202603	0.000133676	4.24618e-05
L2_1	108	0.0866386	0.201562	0.153219	1.77191e-05	0.000295408	0.00012625	5.15651e-05
L3	126	0.0808683	0.181784	0.147125	1.52257e-05	0.000240157	0.000108214	4.56228e-05
L3_1	117	0.0866386	0.212441	0.149458	2.14079e-05	0.000215101	0.000116538	3.6214e-05
L4	111	0.0866386	0.188876	0.155371	3.00096e-05	0.000298152	0.000122838	4.29263e-05
L4_1	116	0.0924889	0.198741	0.150177	2.02325e-05	0.000217307	0.000117543	4.42219e-05

Figure 4-16: Mesh Statistics

2. Click **Close**.

5 - Evaluate Results

To evaluate the bandpass filter, you will create 2D plots and a field overlay of the simulation results. This chapter includes the following sections:

- Create an S-parameter vs. frequency plot
- Compare S12 with S21 to verify device symmetry
- Change the plot scale
- Create an E Field overlay
- Modify the plot attributes and create a phase animation
- Create a frequency animation

Create S-Parameter vs. Frequency Plot

1. In the Project Manager window, right-click **Results** and select **Create Terminal Solution Data Report > Rectangular Plot** from the shortcut menu.

The *Report* dialog box appears.

2. Specify the settings shown in the following figure:

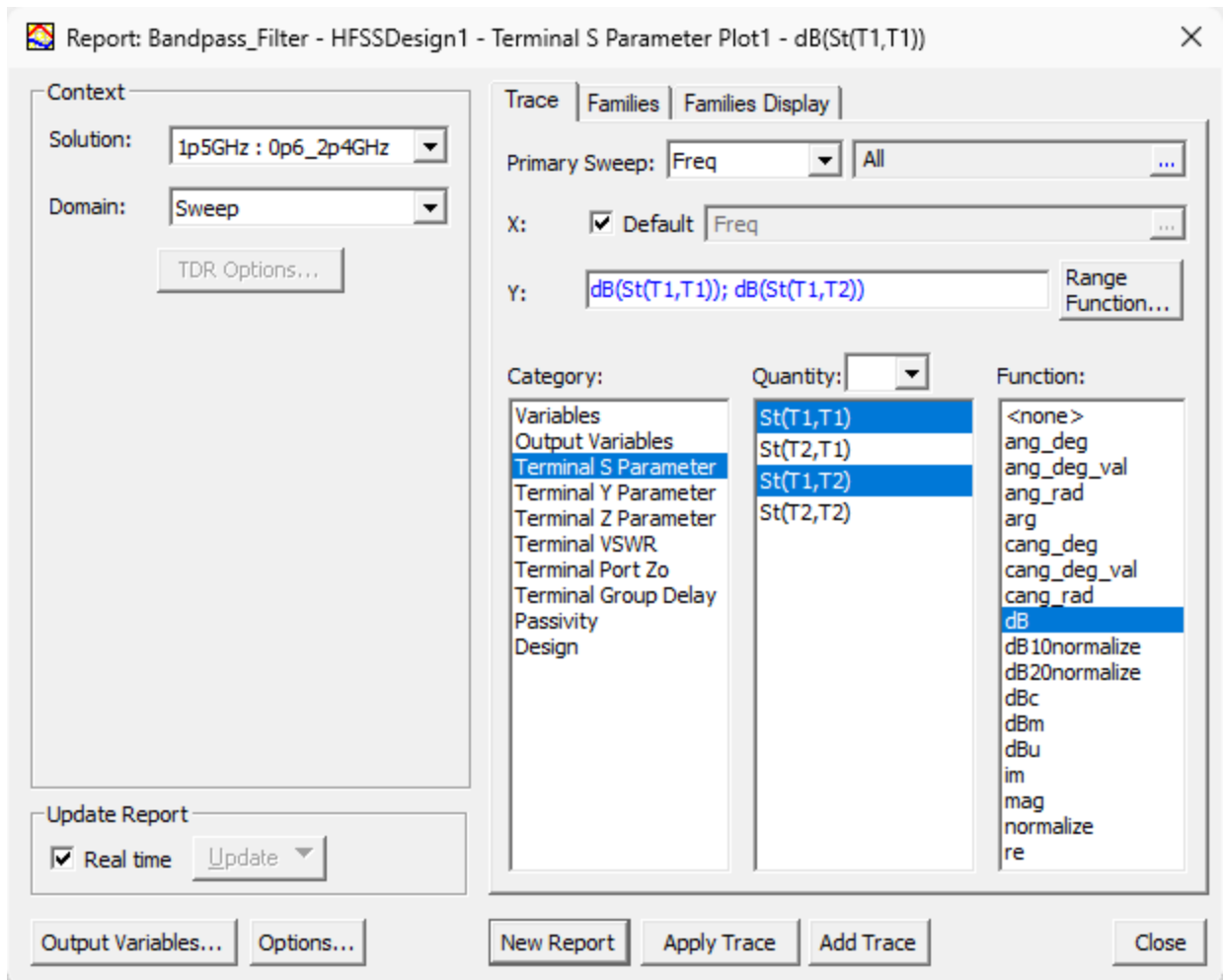

Figure 5-1: Report Dialog Box

3. Click **New Report** but leave the *Report* dialog box open, since you will be adding another trace to the plot in the next topic.

The *Terminal S Parameter Plot 1* appears.

4. Double click on the curve legend.

The *Properties* dialog box appears.

5. On the **Legend** tab, clear the **Show Solution Name** and **Show Variation Key** options.
6. Click **OK** to close the *Properties* dialog box.
7. Drag the simplified legend to the position shown in the figure below and click in a blank area of the plot window (outside of the grid area) to clear any selection.

The plot should resemble the following figure:

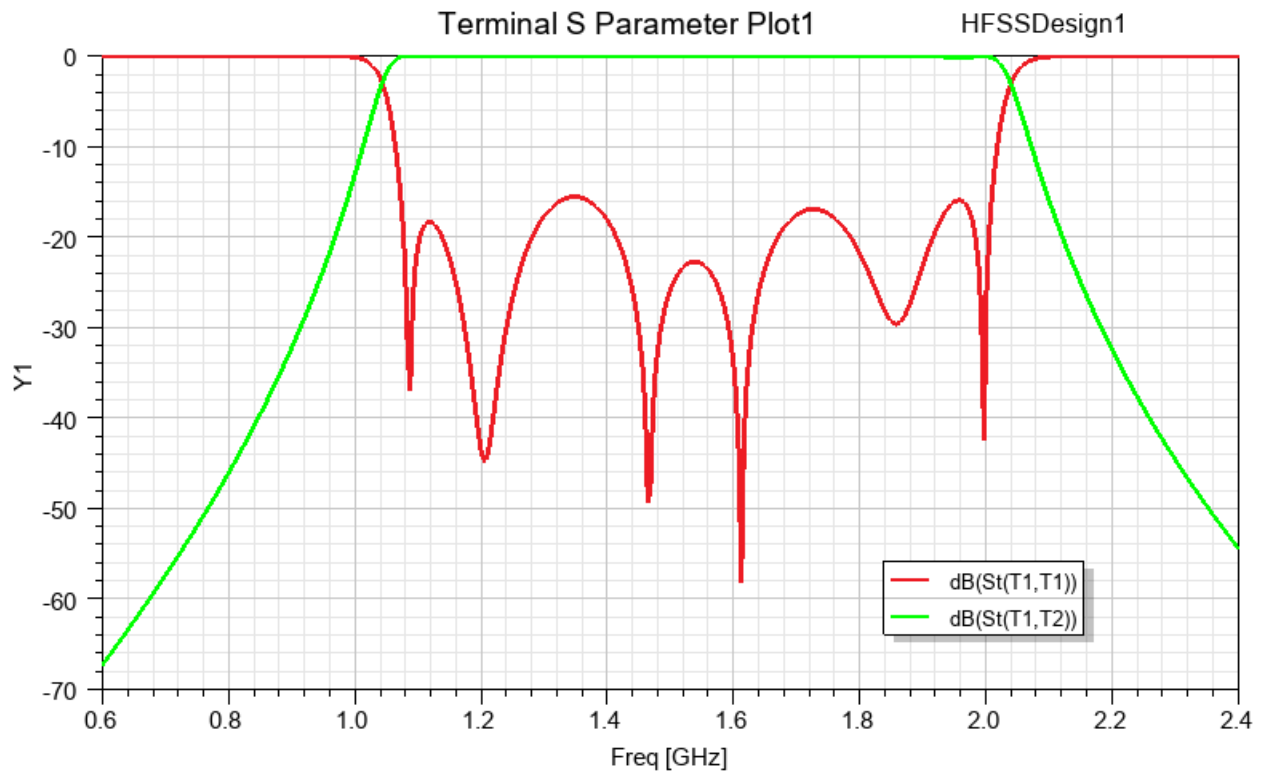

Figure 5-2: S-Parameter versus Frequency Plot

The figure shows the characteristics of a typical bandpass filter with almost 0dB insertion loss and reflection of -15dB or less throughout the pass-band.

Compare S12 with S21

You can verify the symmetry of the bandpass filter by comparing $S(T1,T2)$ with $S(T2,T1)$. To do this, modify the existing S-parameter plot as shown below.

1. If you didn't leave the Report dialog box open in the previous operation, right-click the existing plot in the Project Manager (**Terminal S Parameter Plot 1**) and select **Modify Report** from the short-cut menu.

The **Reports** dialog box appears.

2. Enter the following fields:
 - **Solution:** *1p5GHz : 0p6_2p4GHz*
 - **Domain:** *Sweep*
 - **Quantity:** *$S(T2,T1)$*
 - **Function:** *dB*
3. Click **Add Trace** and click **Close**.

An additional trace is added to *Terminal S Parameter Plot 1*. However, you will not be able to see three traces, just a change in the color of one curve and an additional entry in the legend.

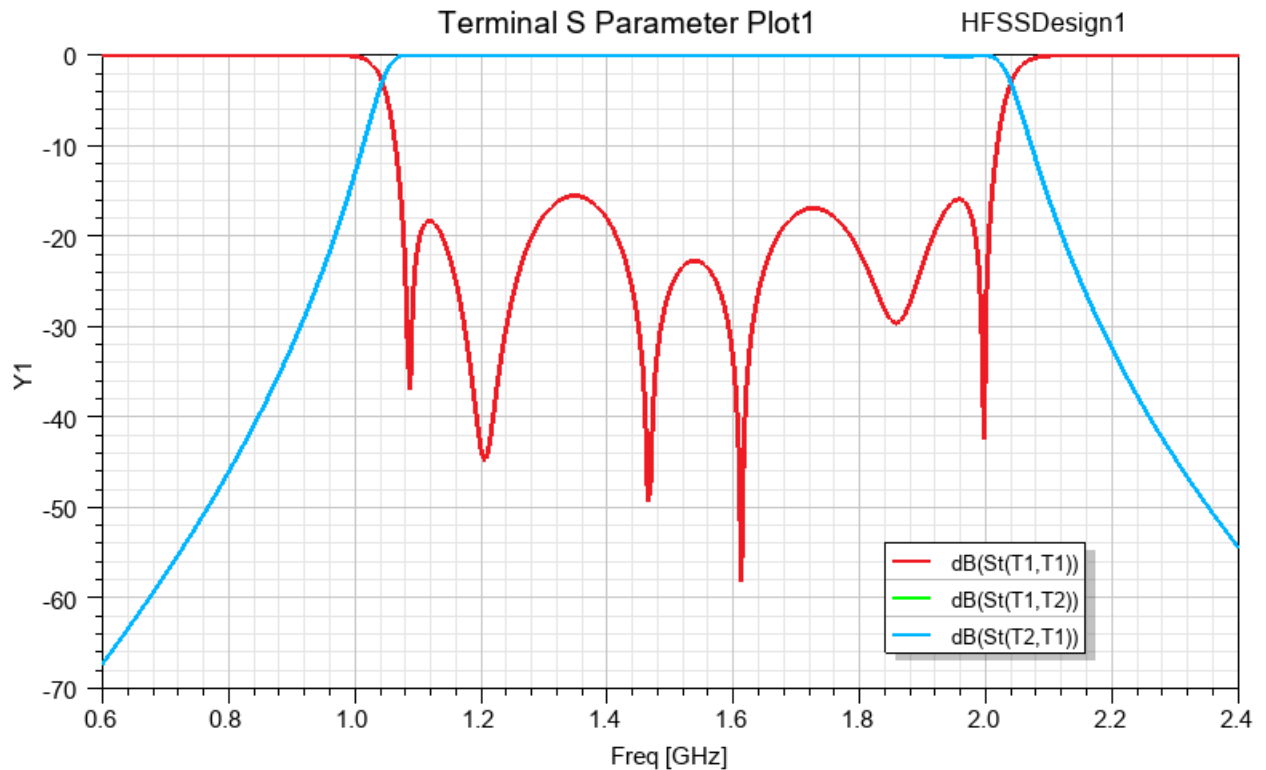

Figure 5-3: S Parameter vs Frequency with Third Trace Added

Explanation: The curves $\text{dB}(\text{St}(\text{T2},\text{T1}))$ and $\text{dB}(\text{St}(\text{T1},\text{T2}))$ coincide perfectly, so they look like a single curve. By hovering the cursor over a trace listed in the legend, you can highlight the curve of interest. The curve color will change to green when the cursor is pointing to the corresponding trace label in the legend.

Change Plot Scale

In order to see the noise in the insertion loss you can zoom into the plot where the S12 curve plateaus.

To zoom into the area of interest on the plot, change the scale of the Y axis as shown below.

1. Double click the Y-axis.

The *Y Axis Properties* dialog box appears.

2. On the **Y1 Scaling** tab, make the following changes:

- a. Select the **Specify Min** option.
- b. Type **-1** in the **Min:** text box.
- c. Select the **Specify Max** option.
- d. Type **0** in the **Max:** text box.

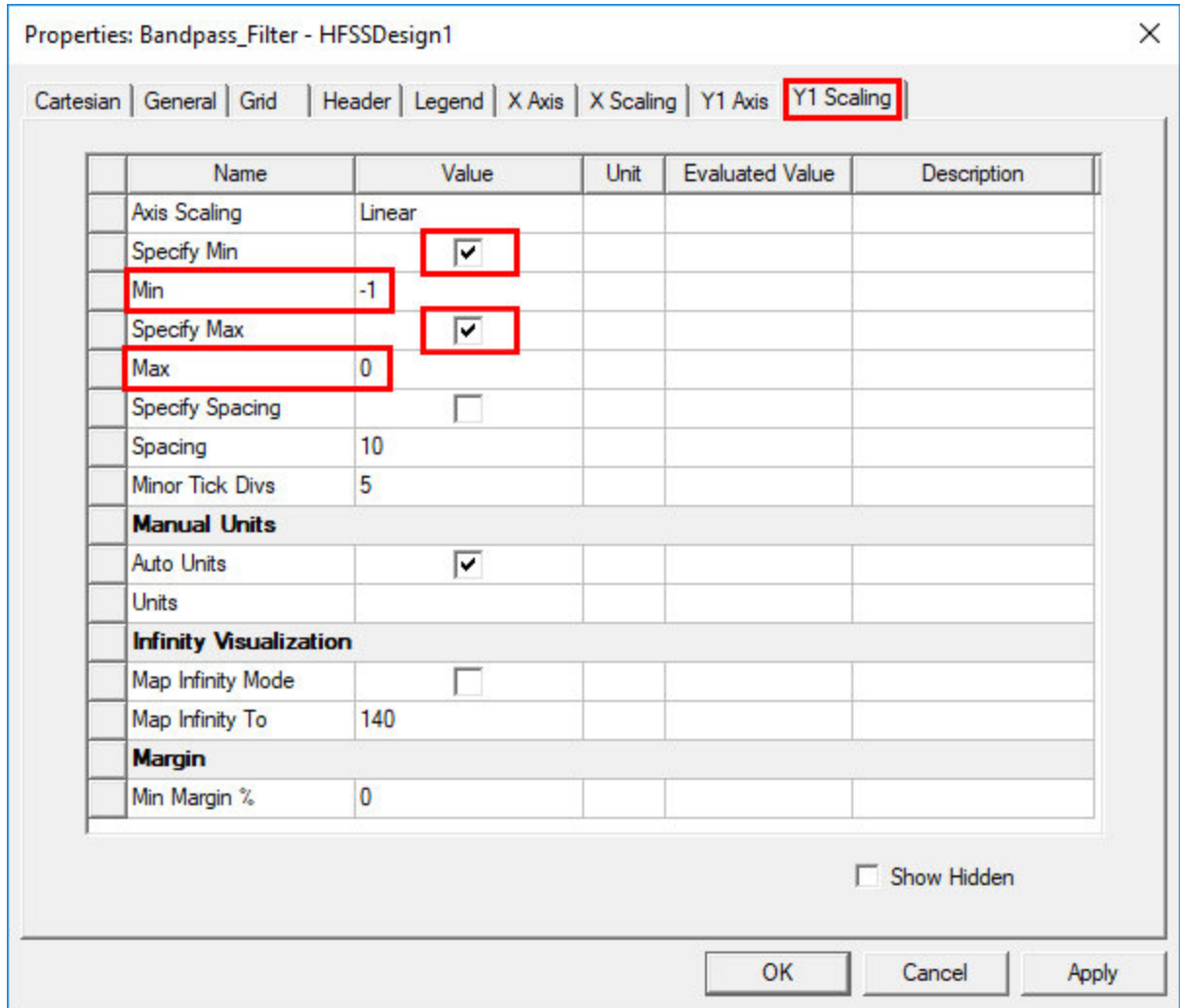

Figure 5-4: Y1 Scaling Properties

- 3. Click **OK** and clear the axis selection.

Your modified plot should resemble the following image:

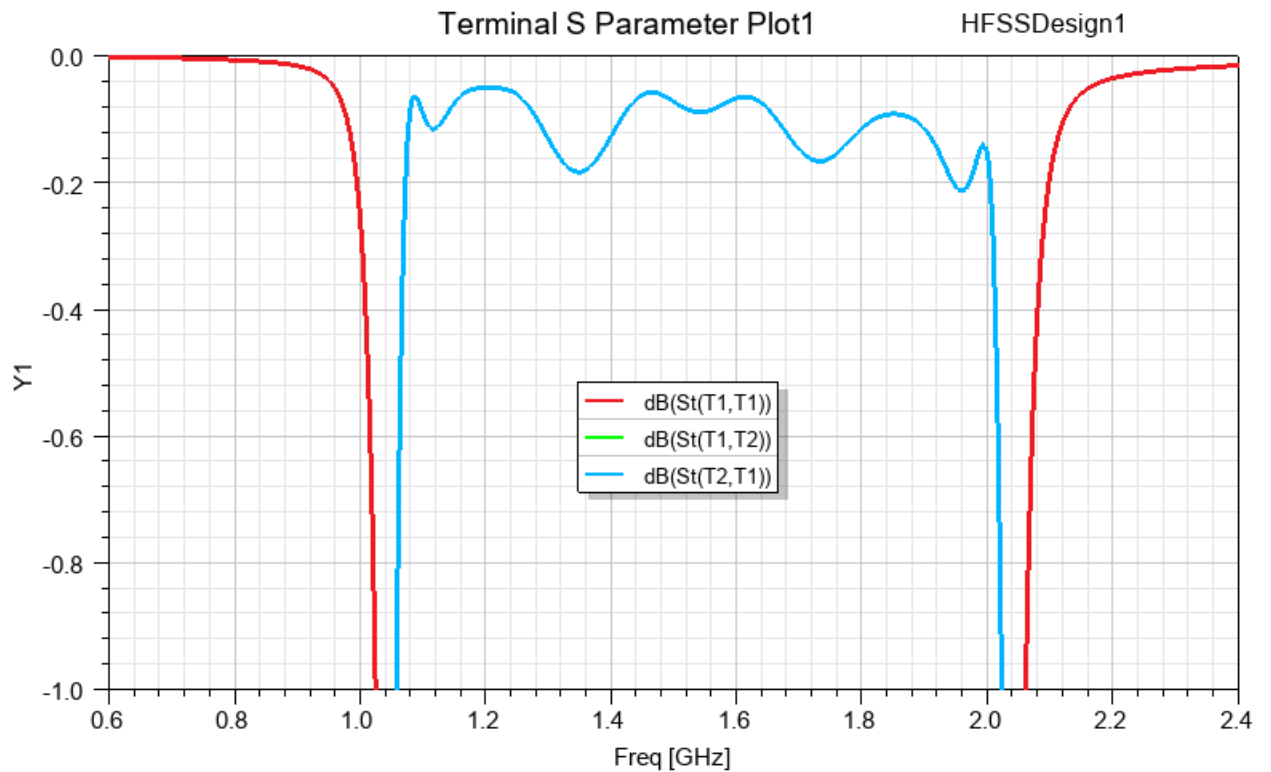

Figure 5-5: S Parameter vs. Frequency Plot with Modified Y Scaling

Create Field Overlays

This section describes how to create field overlays.

1. In the *Project Manager* window, right-click **Field Overlays** and select **Edit Sources** from the short-cut menu.

The *Edit Sources* dialog box appears.

2. Under the **Spectral Fields** tab, set the options as shown in the following figure (in the order indicated by the red numbered boxes) and click **OK**.

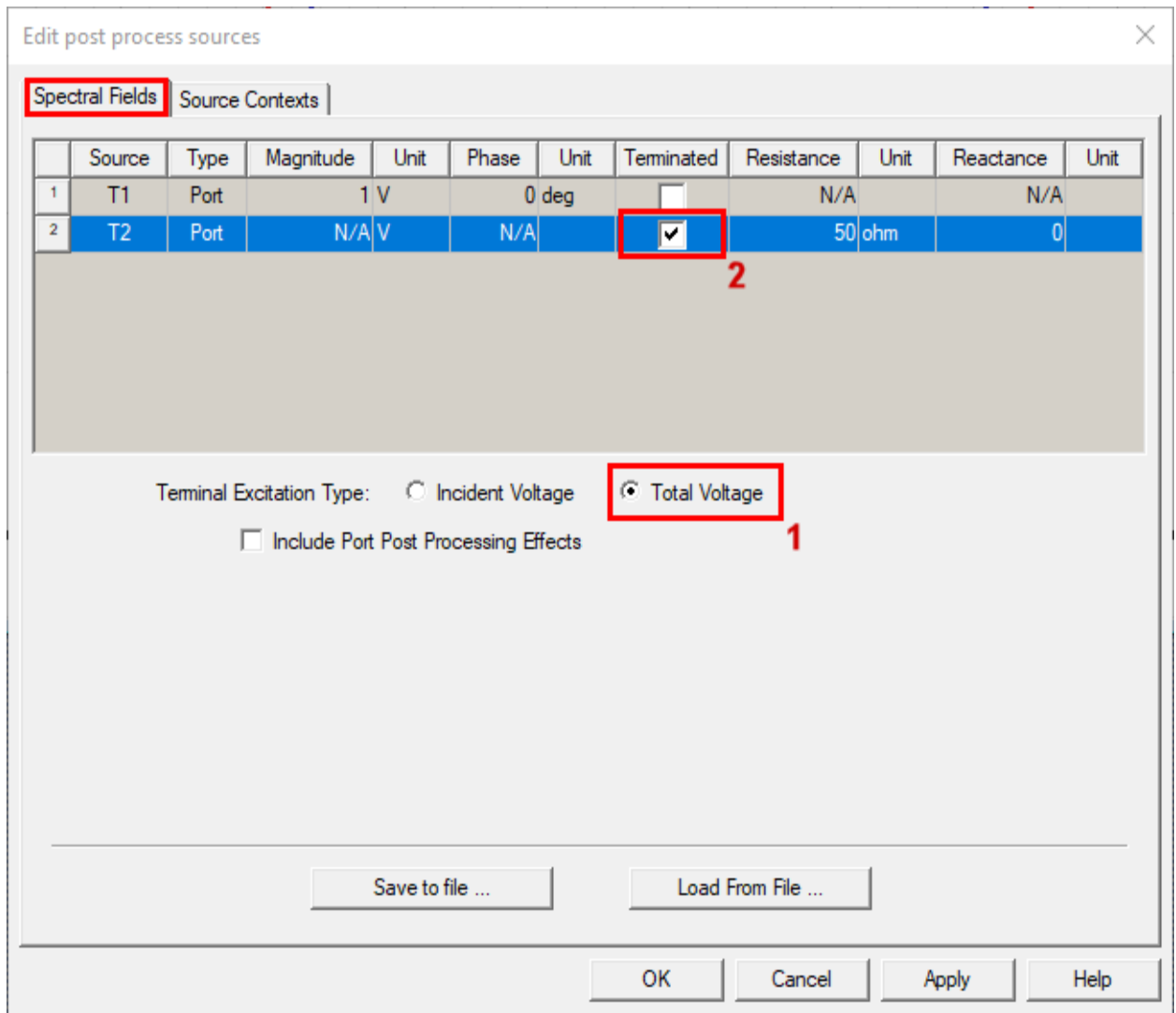
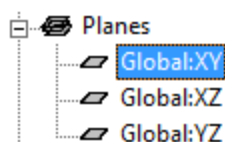

Figure 5-6: Edit Post Process Sources Dialog Box (Total Voltage Selected)

Note:

Total Voltage includes both the *Incident* plus *Reflected* waves in the calculations.

3. Bring the **Modeler** window back to the foreground. You can do so either by closing the plot window or by using the **Window** menu.
4. Expand **Planes** near the bottom of the History Tree and select **Global:XY**.



- Right-click in the Modeler window and choose **Plot Fields > E > Mag_E** from the short-cut menu.

The *Create Field Plot* dialog box appears.

- Set the options as shown in the figure below and click **Done**.

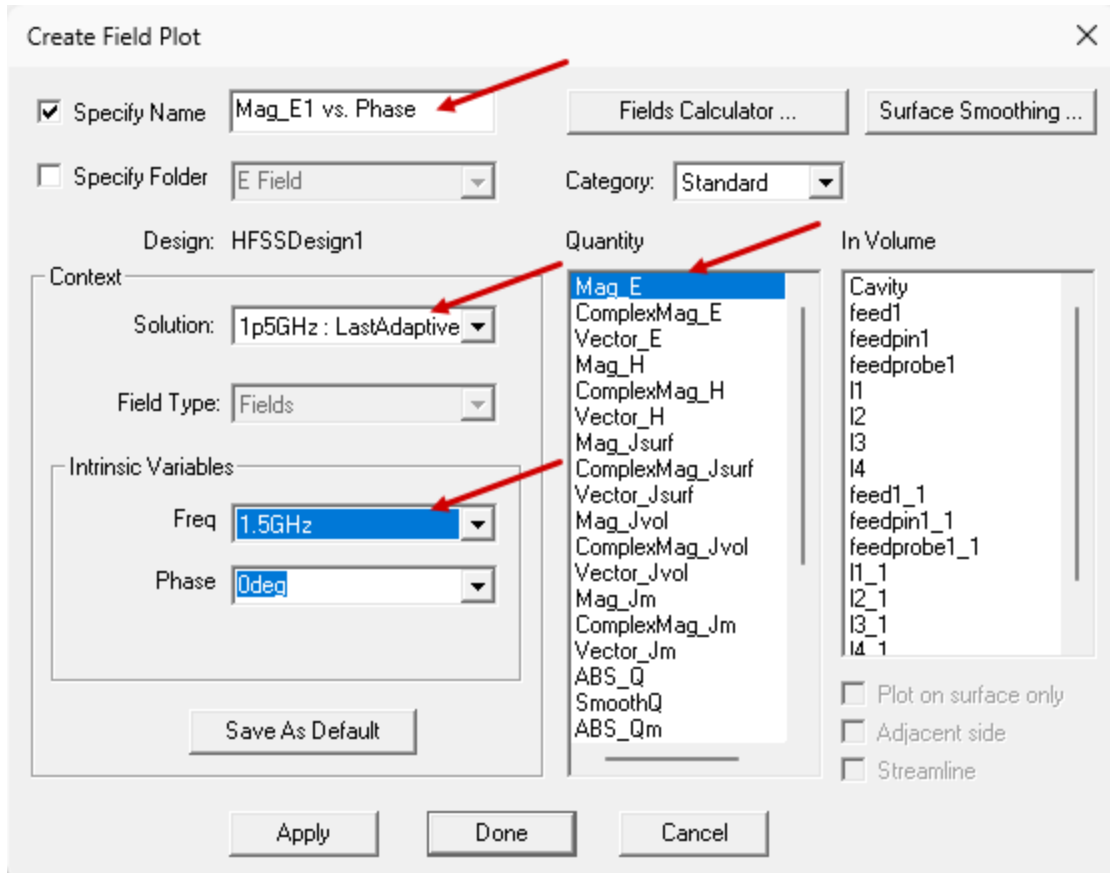

Figure 5-7: Create Field Plot Dialog Box

Modify Plot Attributes

- Double-click the legend to modify the E Field plot attributes.

The *E Field* dialog box appears.

- Select the **Scale** tab, set the options as shown in the following figure, and click **Close**.

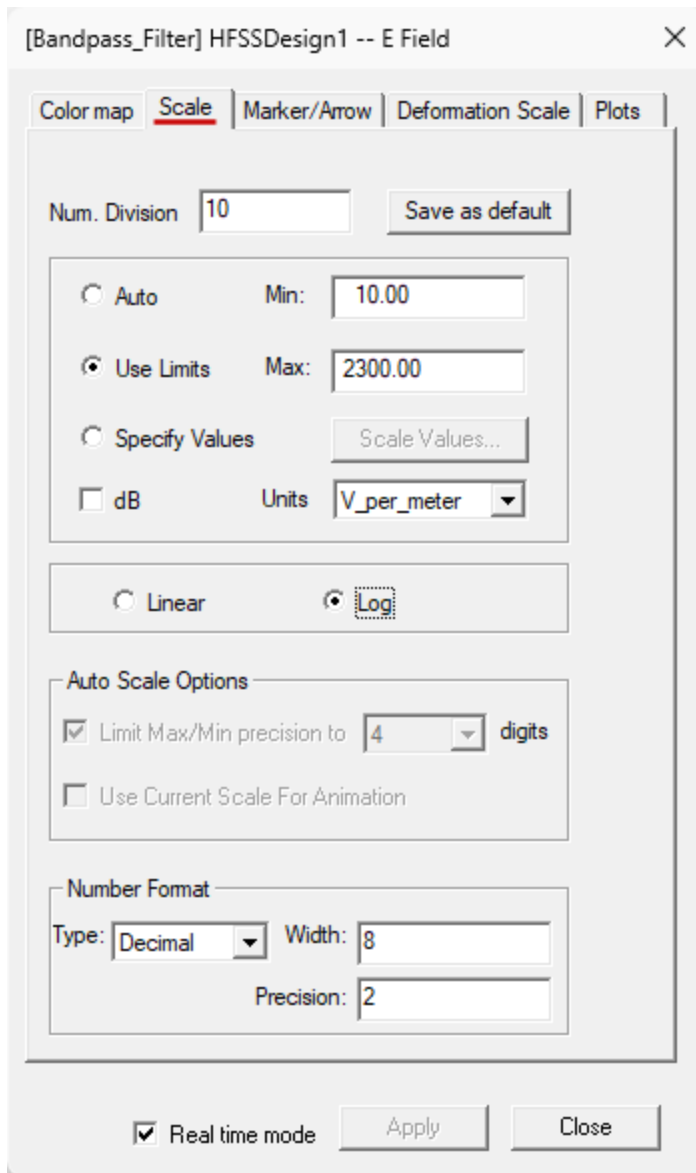

Figure 5-8: E Field Dialog Box (Scale Tab)

Note:

For this model, a logarithmic plot scale, with user-defined range limits, brings out the full spectrum of field contour colors better than a linear scale does. The maximum field intensity varies with phase and frequency, and the modified range was chosen to suit the range of values that will be encountered when the overlay is animated. A log scale cannot begin at zero, and the altered minimum limit enhances the saturation of the blue (minimum) values. The intent of these changes is to make the shape of the field and the way it varies with phase and frequency easier to see.

The legend displays the true min/max values for the initial static overlay, but these values are not updated while animating the overlay. The contour colors are based on the user-specified *Min* and *Max* limits (10–2200 V/M), not the *Min* and *Max* values indicated at the bottom and top of the legend, respectively.

The modified field overlay should look like the following image:

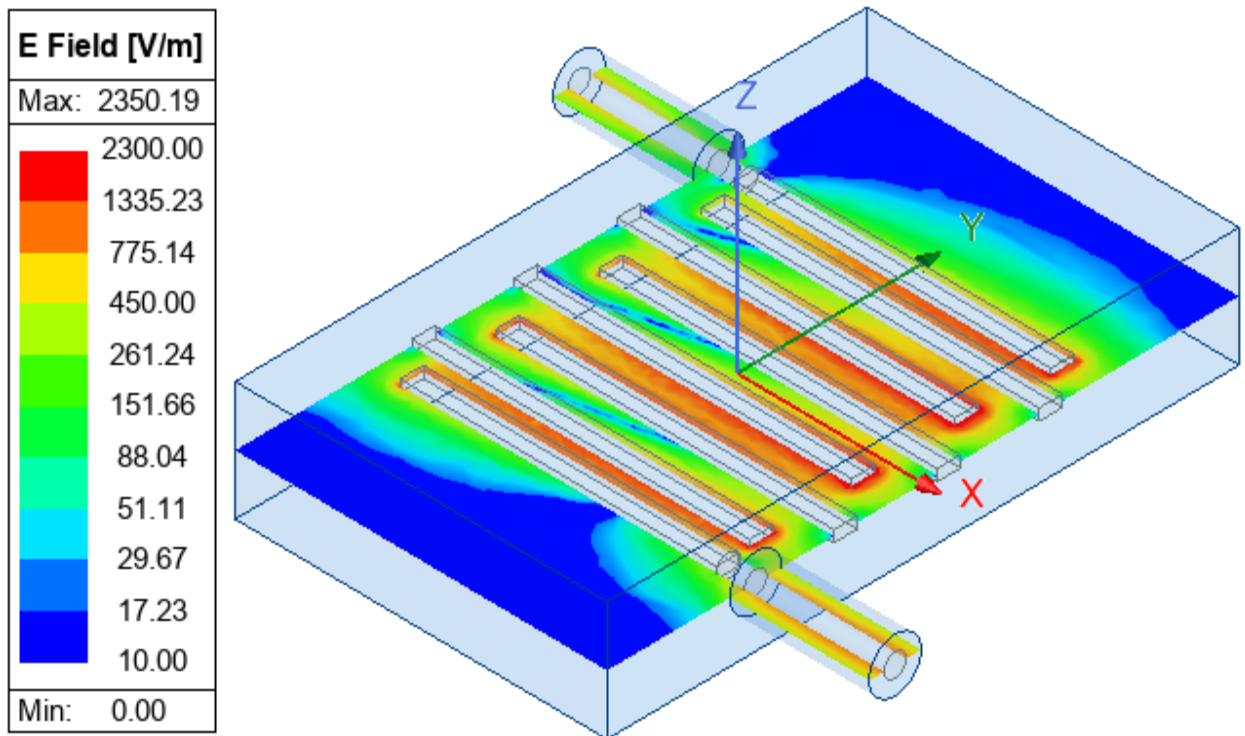

Figure 5-9: Model with E Field Overlay

Other Plot Attributes and Animating Results

You may also wish to experiment with available settings on the **Color Map** tab and the **Plots** tab to see how different settings can modify the appearance of the field plot.

To look at a phase animation of the E field, do as follows:

1. Under *Field Overlays* > *E Field* in the Project Manager, right-click **Mag_E vs. Phase** and choose **Animate** from the shortcut menu.
2. In the *Create Animation Setup* dialog box that appears, change the **Name** to **Phase Animation**.
3. Keep the remaining settings at their defaults and click **OK**.
4. Click **Animate**.
5. Optionally, drag the *Phase* annotation to a good location and use the controls in the *Animation* dialog box to start, stop, reverse, or vary the speed of the animation.

Your animation should resemble the one shown below:

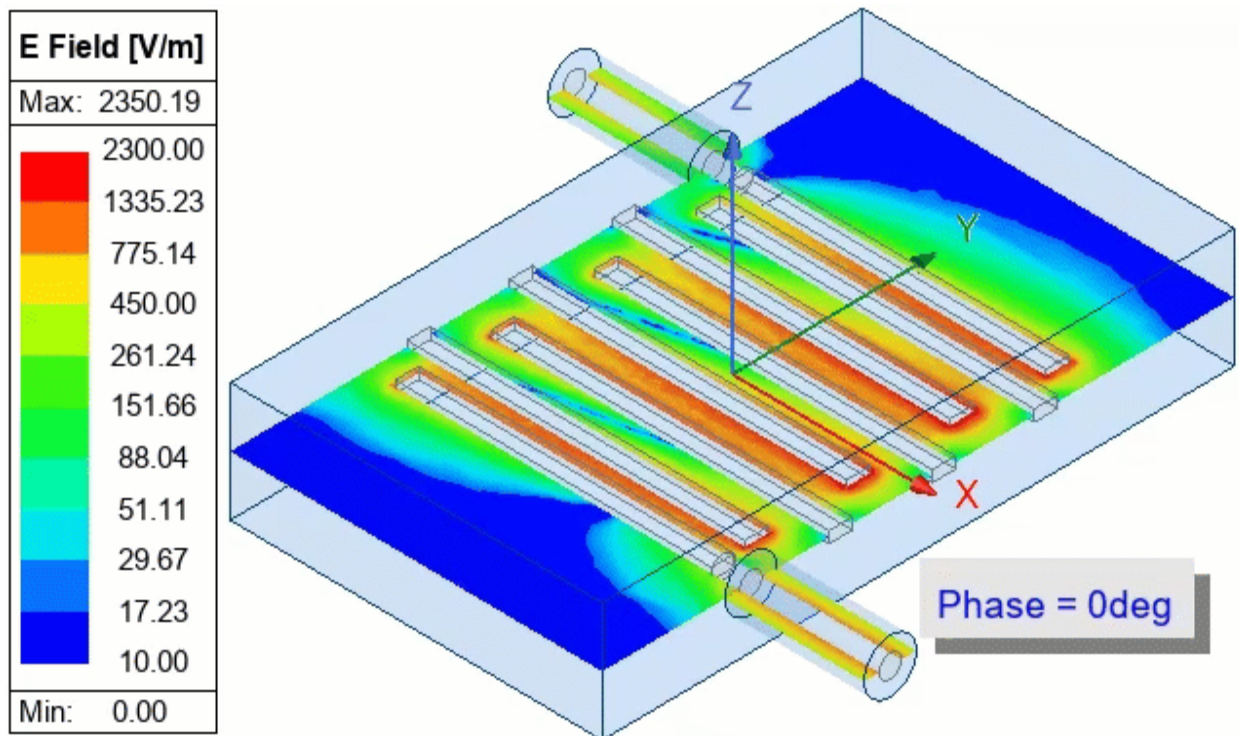

Figure 5-10: E Field versus Phase Animation

6. Close the *Animation* dialog box when you are done viewing the animated fields.

Create a Frequency Animation

1. Under *Planes* in the History Tree, select **Global XY**.
2. Right-click **Field Overlays** in the Project Manager and choose **Plot Fields** > **E** > **Mag_E**.

- Double-click the legend to modify the E Field plot attributes.
- In the *Create Field Plot* dialog box that appears, set the options as shown in the following figure and then click **Done**.

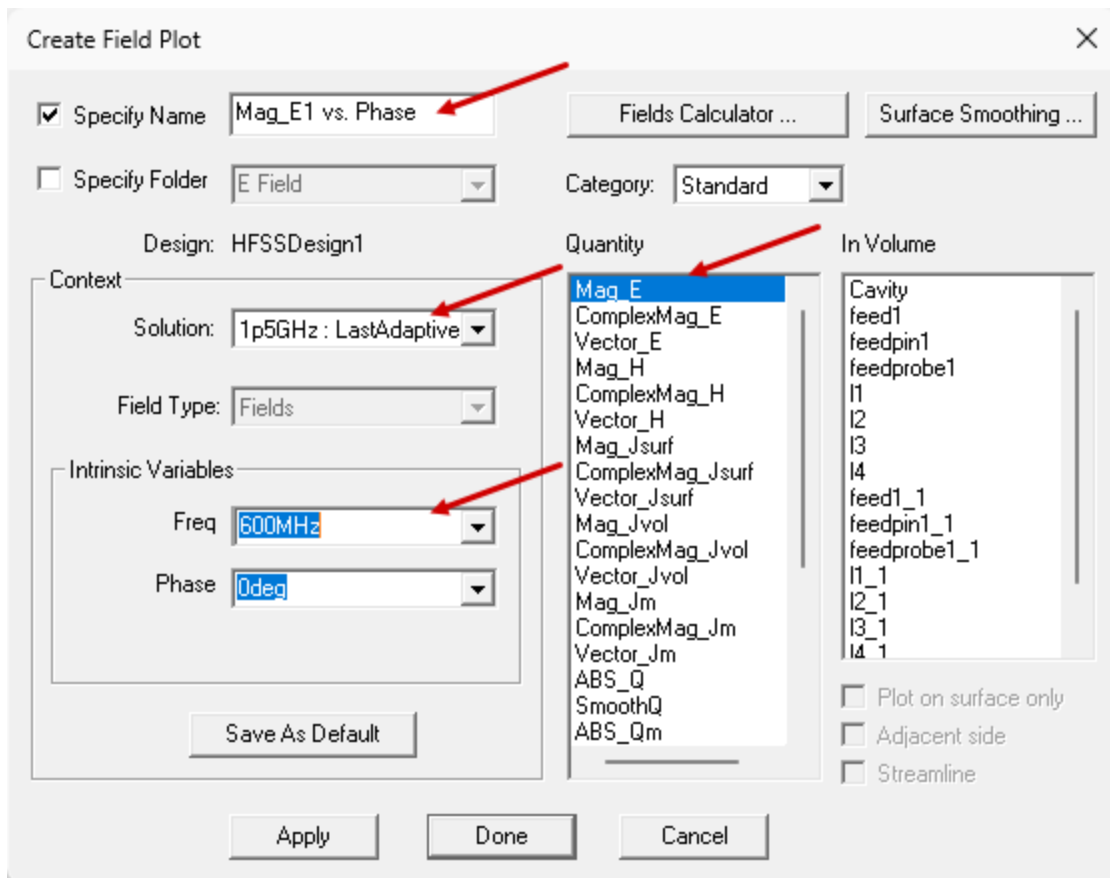

Figure 5-11: Settings for Creating a Second Field Plot

A new field overlay appears in the Modeler window and is listed in the Project Manager. Notice that the legend scale overrides are retained from the previous overlay because the settings apply to all E Field plots.

- Under *Field Overlays* > *E Field* in the Project Manager, right-click **Mag_E vs. Frequency** and choose **Animate** from the shortcut menu.
- In the *Select Animation* dialog box that appears, click **New**.
- In the *Create Animation Setup* dialog box that appears, change the **Name** to **Frequency Animation** and specify the settings shown in the following image. Then click **OK**.

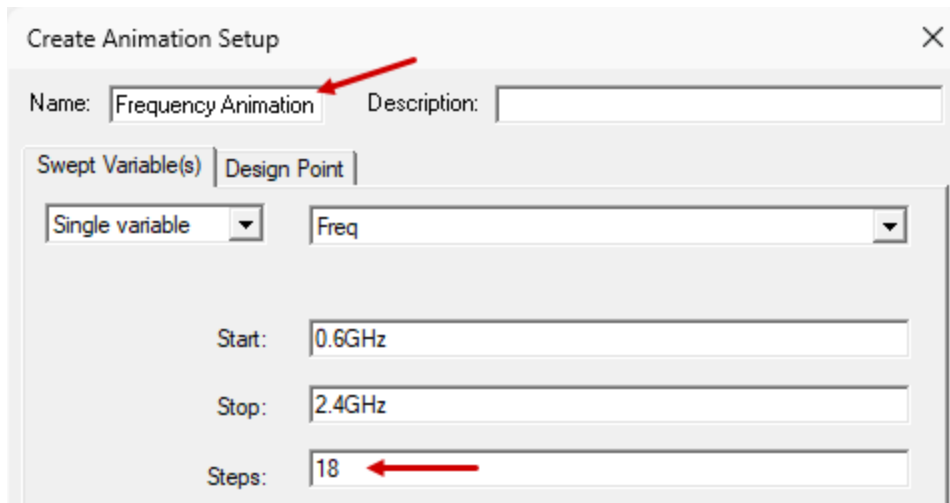
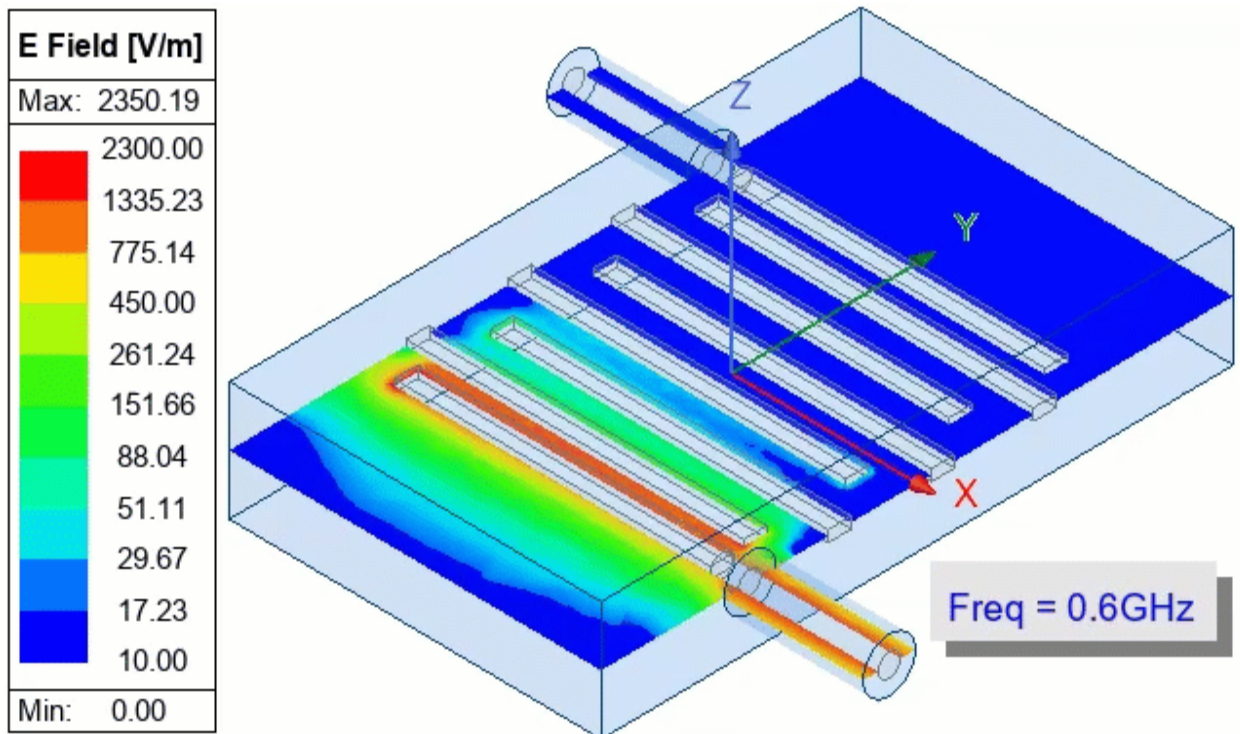

Figure 5-12: Frequency Animation Settings

8. With the *Frequency Animation* setup selected, click **Animate**.
9. Optionally, drag the *Phase* annotation to a good location and use the controls in the *Animation* dialog box to start, stop, reverse, or vary the speed of the animation.

Your animation should resemble the one shown below:



This animation is best viewed at a slow speed. Notice how a significant field strength only reaches the output port for frequencies from 1.0 to 2.1 GHz, inclusive, with some

attenuation occurring at 1.0 and 2.1 GHz. For frequencies outside of this range, the E field is effectively blocked from reaching the output port.

10. Close the *Animation* dialog box when you are done viewing the frequency animation.

6 - Set Up and Run HFSS Multipaction Analysis

This chapter shows how to run an HFSS Multipaction Analysis using the Bandpass Filter model just completed. You will duplicate the original design to preserve its solution results. After running an initial multipaction analysis, you will duplicate that design to create a second multipaction analysis, to which you will add a DC bias to the vacuum objects. Finally, you will compare the multipaction results with and without the DC bias assigned.

A slight modification of the geometry is required to make the model suitable for the multipaction additional analyses. Complete the following steps to add and solve the multipaction analysis:

HFSSDesign1:

- Duplicate the existing HFSS design to preserve its results

Multipaction1:

- Imprint *Feed1* and *Feed1_1* on the *Enclosure*
- Assign Secondary Electron Emission (SEE) boundaries to the vacuum/metal interface surfaces where multipaction will occur
- Assign multipaction charge region excitations
- Add a discrete sweep as the basis of the multipaction analysis
- Add and Solve the multipaction analysis, specifying a 6 nanosecond duration and four different power multipliers
- Plot the number of particles versus time
- Create and animate a particle overlay
- Create a duplicate of the *Multipaction1* design

Multipaction2:

- Add a Multipaction DC bias to the vacuum objects
- Solve the second multipaction analysis and compare results to the first one

For more information, see the [HFSS Multipaction Analysis](#) help topic.

Duplicate HFSSDesign1

In later steps, you will modify the geometry of the model in preparation for setting up and solving a multipaction analysis, which will invalidate the results of HFSSDesign1. To preserve the existing solution results, duplicate the first design and modify the newly added second design.

1. In the Project Manager, right-click **HFSSDesign1 (Hybrid Terminal Network)** and choose **Copy** from the shortcut menu.
2. At the top of the Project Manager, right-click **Bandpass_Filter** and choose **Paste..**
3. Collapse the **HFSSDesign1 (Hybrid Terminal Network)** branch of the Project Manager

4. Expand the **HFSSDesign2 (Hybrid Terminal Network)** branch of the Project Manager
5. With **HFSSDesign2 (Hybrid Terminal Network)** selected, press **F2** to rename the second design. Name it **Multipaction1**.
6.  **Save** the Project.

The appearance of the Project Manager should be as shown in the following figure:

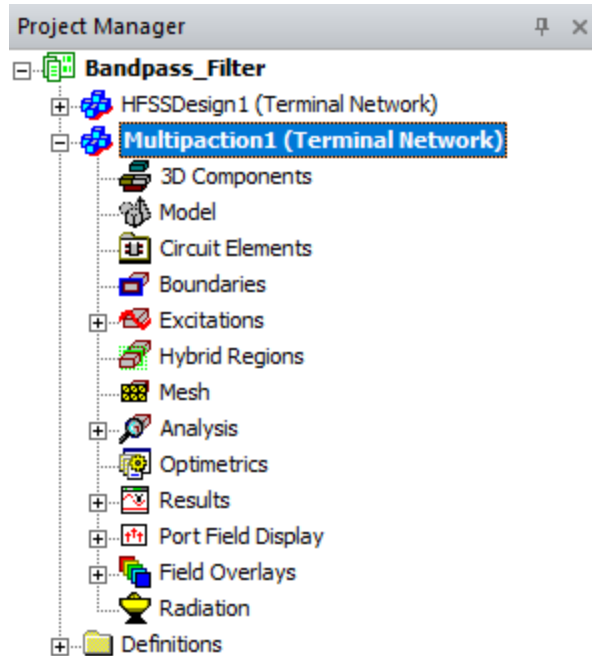



Figure 6-1: Multipaction1 Design Created

Imprint Feeds on Enclosure

In a later procedure, you will assign an SEE boundary to the outside faces of the enclosure. However, the *Feed1* and *Feed1_1* vacuum objects intersect the front and back sides of the enclosure, respectively. It would be incorrect to place an SEE boundary at the place where two vacuum parts meet. SEE boundaries represent vacuum-to-metal interfaces where multipaction effects can occur.

You will use the *Imprint* tool to split the front and back faces of the enclosure at the feed intersections. The result will be that the areas of intersection become separate enclosure faces, and you can exclude these small circular faces when assigning the SEE boundary.

1. Under *vacuum* in the History Tree, select **Enclosure**, **Feed1**, and **Feed1_1** (in that specific order).
2. On the **Draw** ribbon tab, click  **Imprint** or, using the menu bar, click **Modeler > Boolean > Imprint**.

The *Imprint* dialog box appears:

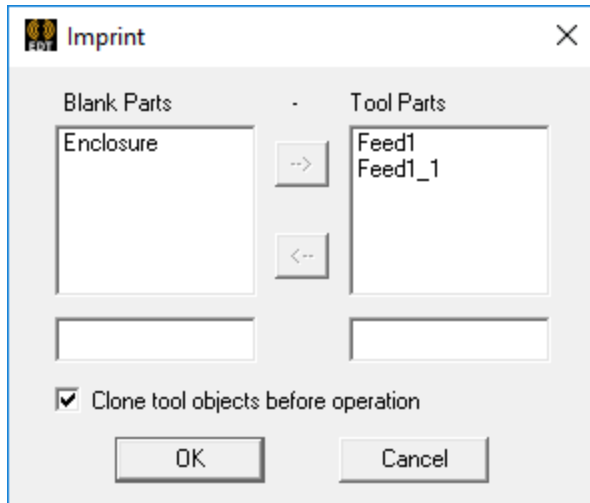

Figure 6-2: Imprint Dialog Box

3. Ensure that:
 - **Enclosure** is listed under *Blank Parts*
 - **Feed1** and **Feed1_1** are listed under *Tool Parts*
4. Select **Clone tool objects before operation**.
5. Click **OK**.

Note:

When the first design was duplicated, its results were not copied to the new design. This is of no concern. You will choose an option when setting up the multipaction analysis that will solve the HFSS setup if needed.

6. In **Face** selection mode, click the front and back faces of the enclosure to verify the imprinting results.

The circular faces at the feed intersections should not be highlighted in magenta, indicating that these faces are excluded from the larger front and back faces:

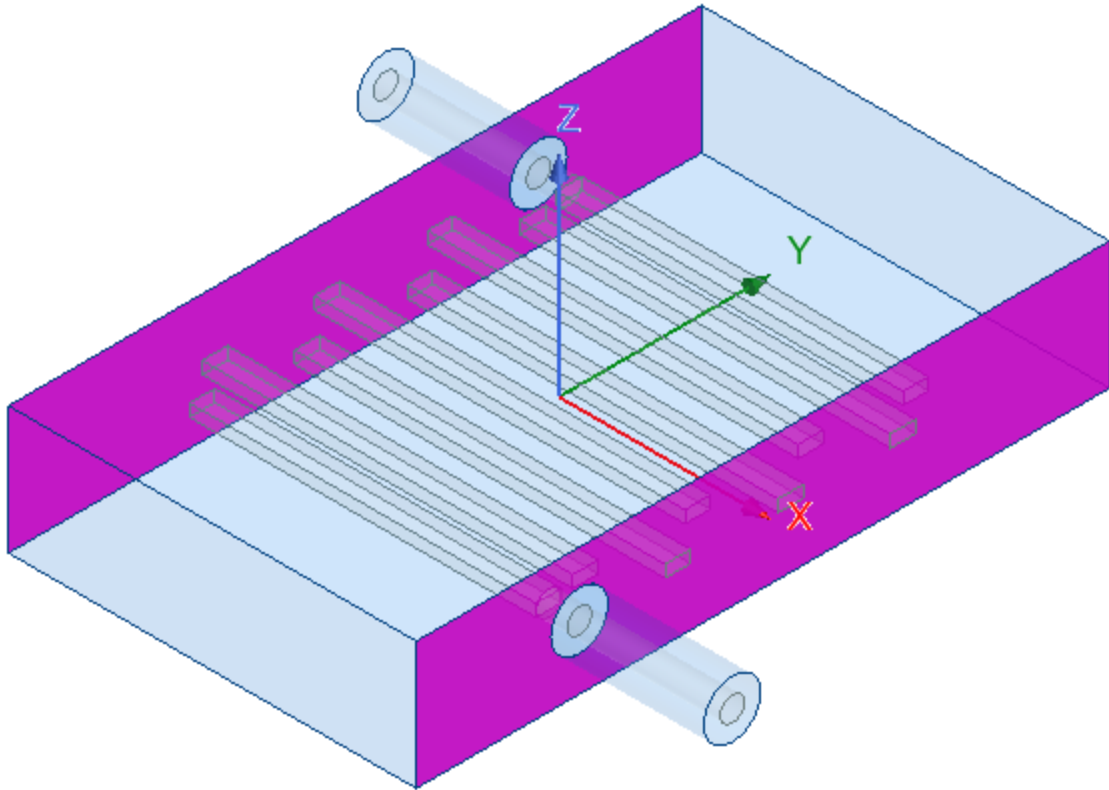

Figure 6-3: Imprinting Results Verification

7. Keep these faces selected. In the next procedure, you will select additional faces and assign the SEE boundary.

Assign SEE Boundaries

The Secondary Electron Emission (SEE) boundaries define vacuum-to-metal interfaces where secondary electrons will be generated. For this model, the first boundary represents the inside surfaces of the metal case enclosing the vacuum and conducting parts. This case is not actually included in the model.

You will also define a second SEE boundary surrounding all of the conducting objects.

For the first SEE boundary, you will select individual *faces* of the vacuum objects. For the second, you will select the conducting *objects*, and the boundary will be applied to all the object faces.

1. In addition to the **front** and **back** faces of the enclosure already selected, hold down the **Ctrl** key and click to select the **top**, **bottom**, **left**, and **right** faces of the enclosure too. Rotate the view orientation as needed or press **B** to select a face that is behind an initially selected face.
2. Holding down **Ctrl**, also click to select the **outside diameter face of each feed**. Do not select the end faces of the Feeds.

The model should look like the following image:

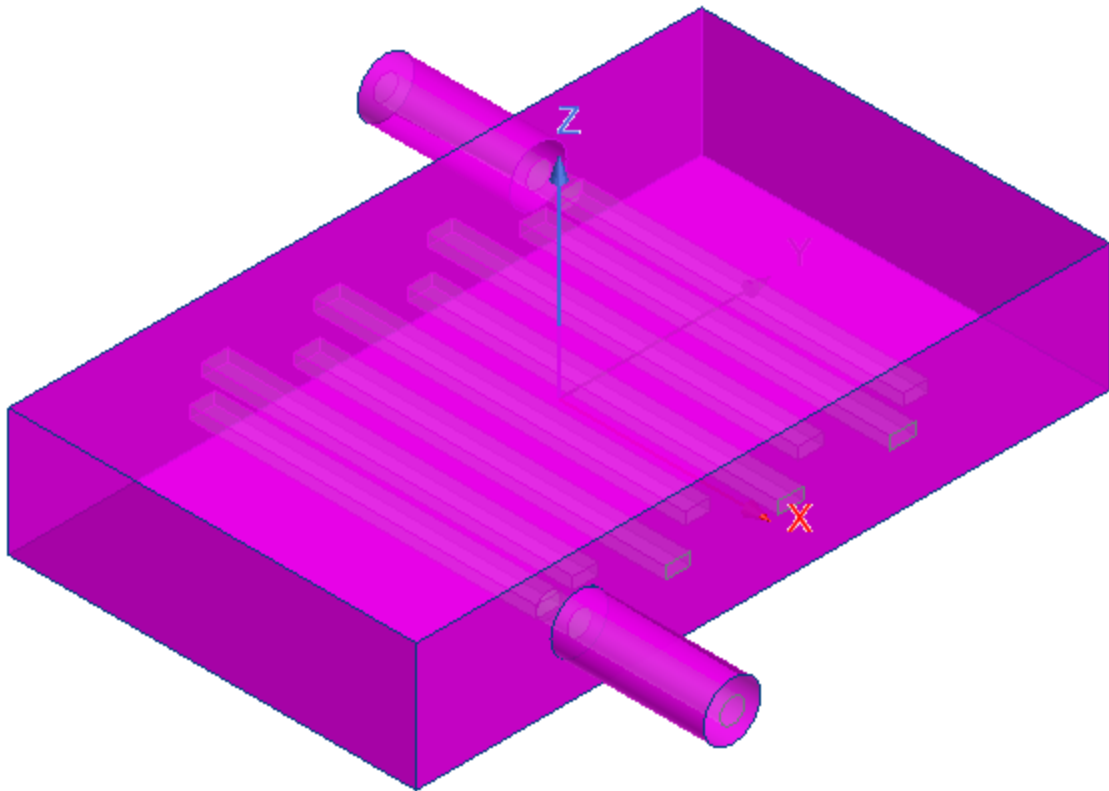

Figure 6-4: Enclosure and Feed SEE Boundary Faces Selected

3. Right-click in the Modeler window and choose **Assign Boundary > Multipaction SEE** from the shortcut menu.

The *Multipaction SEE* dialog box appears:

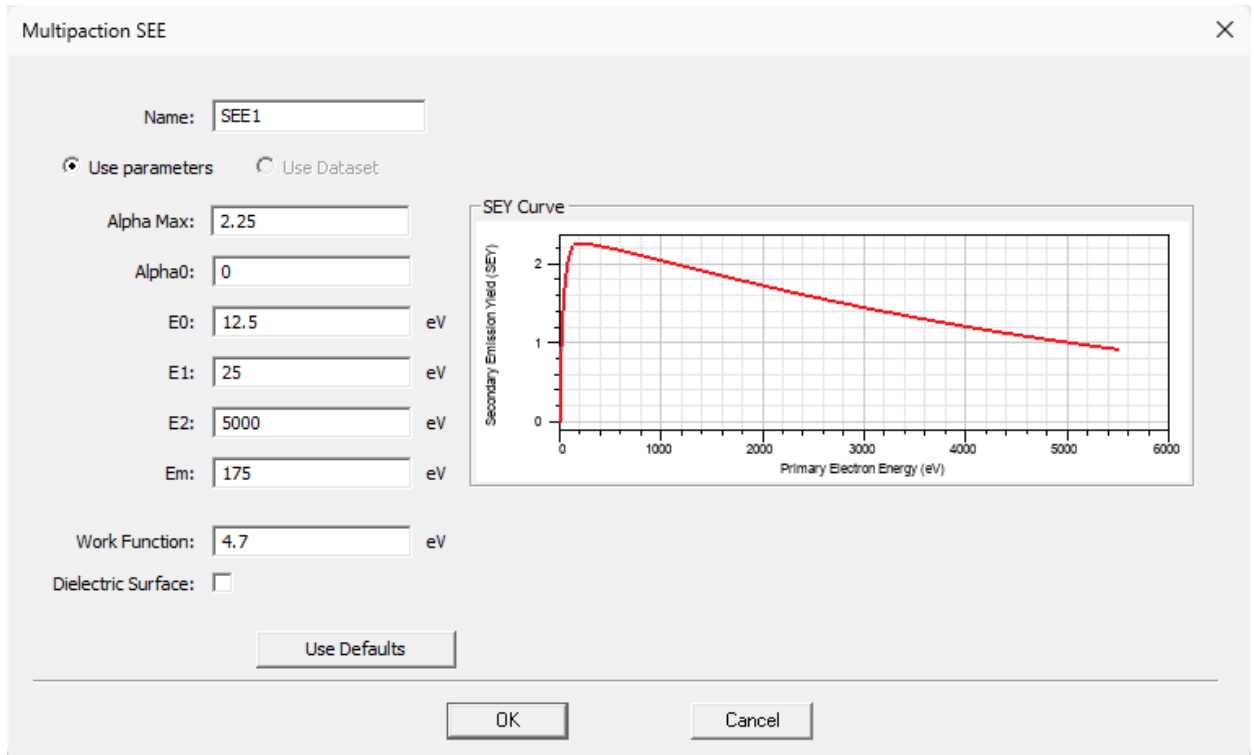

Figure 6-5: Multipaction SEE Dialog Box

4. Verify that the default settings match the preceding figure and click **OK** to assign the boundary.

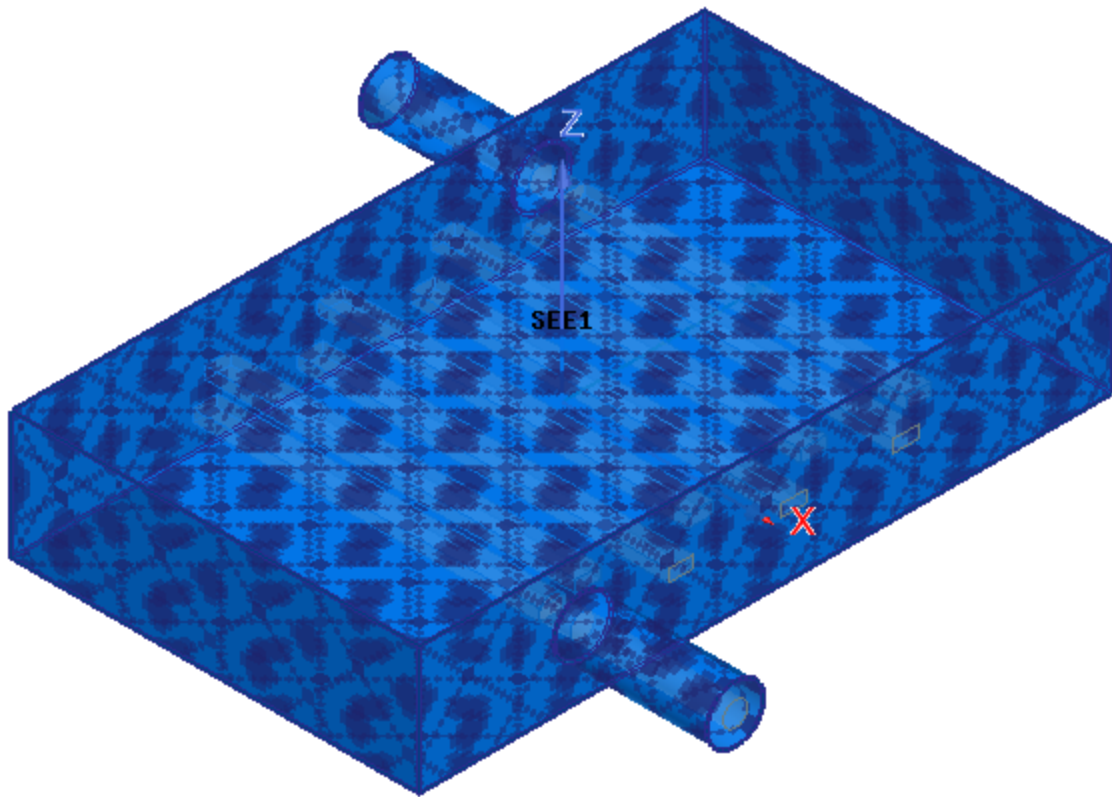

Figure 6-6: Boundary SEE1 Assigned

5. Click in the background area to clear the current selection.
6. Press **O** to switch to the **Object** selection mode.
7. Under *Model > Solids > pec* in the History Tree, select **Feed1**.
8. Shift-click **L4** (also under *Model > Solids > pec*) to select all of the remaining conductor objects too:

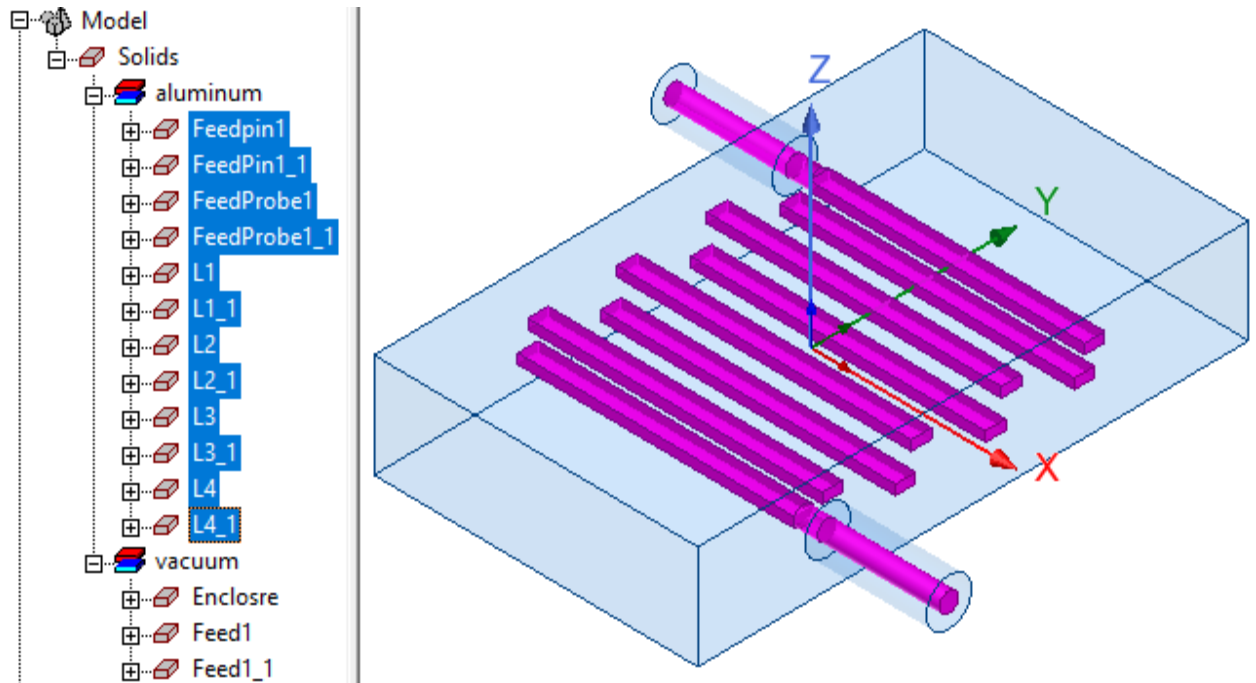

Figure 6-7: Conducting Objects Selected

9. Right-click in the Modeler window and choose **Assign Boundary > Multipaction SEE**
10. Again, accept the default settings, as shown in the preceding dialog box figure and click **OK**.

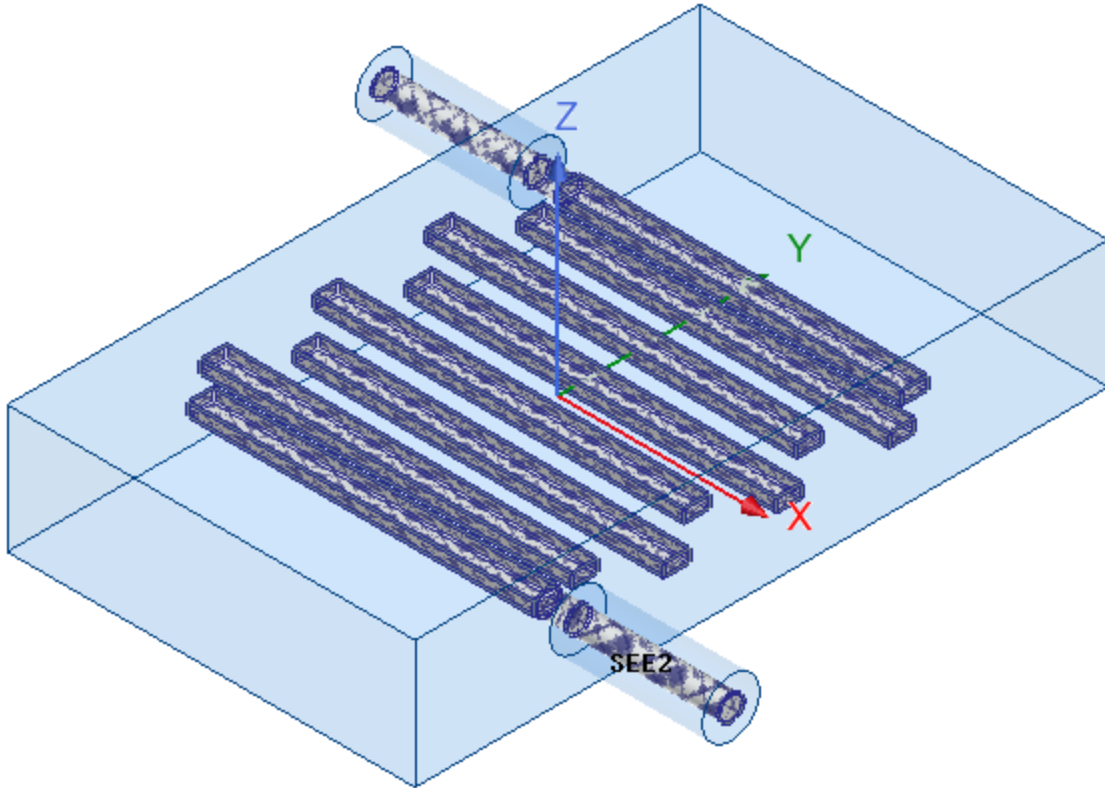

Figure 6-8: Boundary SEE2 Assigned

11. Click in the background area to clear the current selection.

Assign Charge Region Excitations

The properties of a multipaction charge region define the initial number of particles and their charge, mass, and initial velocity components. You will define charge regions with 200 particles per vacuum object and default values for the remaining properties.

If you were to assign a charge of 600 particles to all three vacuum objects in a single operation, the number of particles would be distributed uniformly throughout the combined volume of the selected objects. The majority of the particles would be applied to the largest volume, the enclosure. The density of the particles (number per unit volume) would be constant. For this exercise, we want to assign a 200 particle charge to each object. Since their volumes differ, two separate charge region excitations are required. You can assign a charge with 400 particles to the two feeds in a single operation, since their volumes are identical and both will receive 200 particles. You will have to apply a 200 particle charge to the enclosure separately.

This excitation scheme creates a higher particle density (that is, a higher charge per unit volume) within the coaxial feeds than within the enclosure. It is a well known phenomenon among space component designers that coax feeds are prone to multipaction. Therefore, seeding the feeds with a higher charge helps multipaction to be detected sooner and therefore leads to a shorter solution time.

1. In **Object** selection mode, or using the History Tree, select **Feed1** and **Feed1_1**.

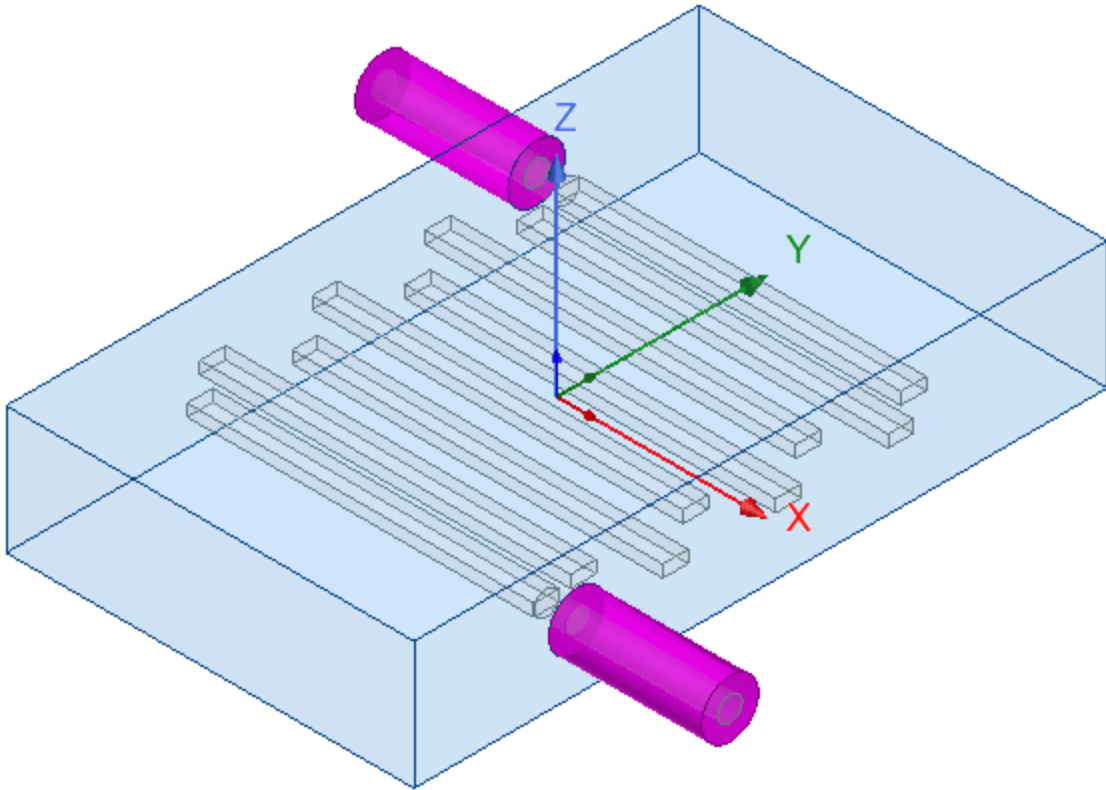

Figure 6-9: Feed1 and Feed1_1 Selected

2. Right-click in the modeler window and choose **Assign Excitation > Multipaction Charge Region**. Then:
 - a. In the *Multipaction Charge Region* dialog box that appears, type **400** in the **Number of particles** text box.
 - b. Ensure that the remaining settings match those shown in the following figure:

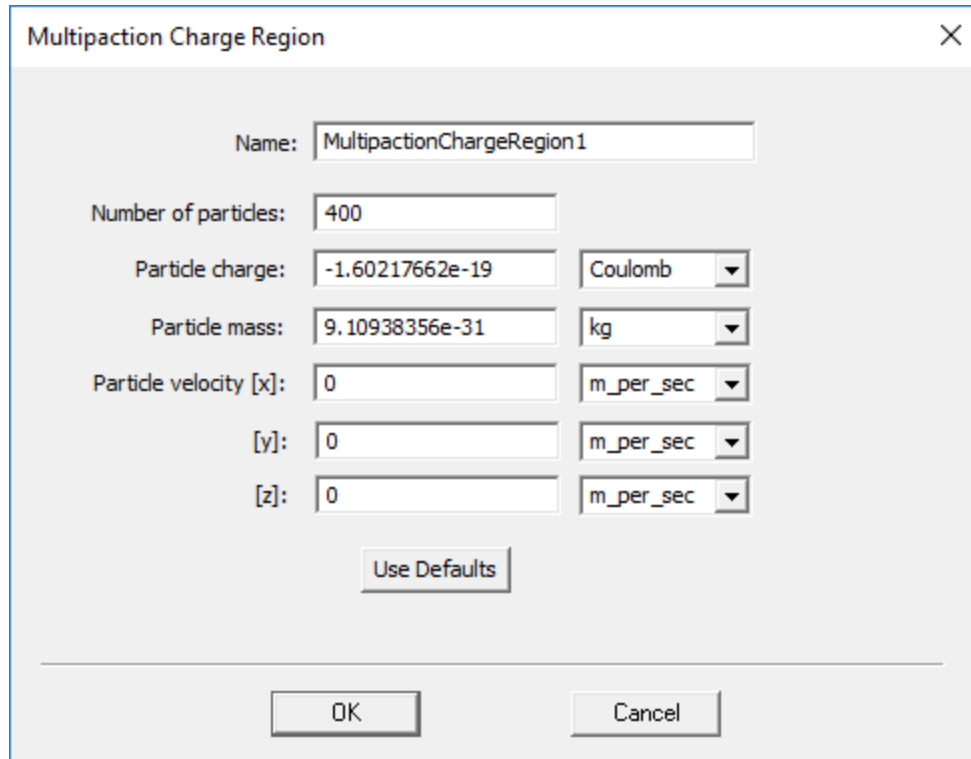

Figure 6-10: Multipaction Charge Region Dialog Box – Settings for Feeds

- c. Click **OK**.

MultipactionChargeRegion1 appears under *Excitations* in the Project Manager, and the model appearance is as follows:

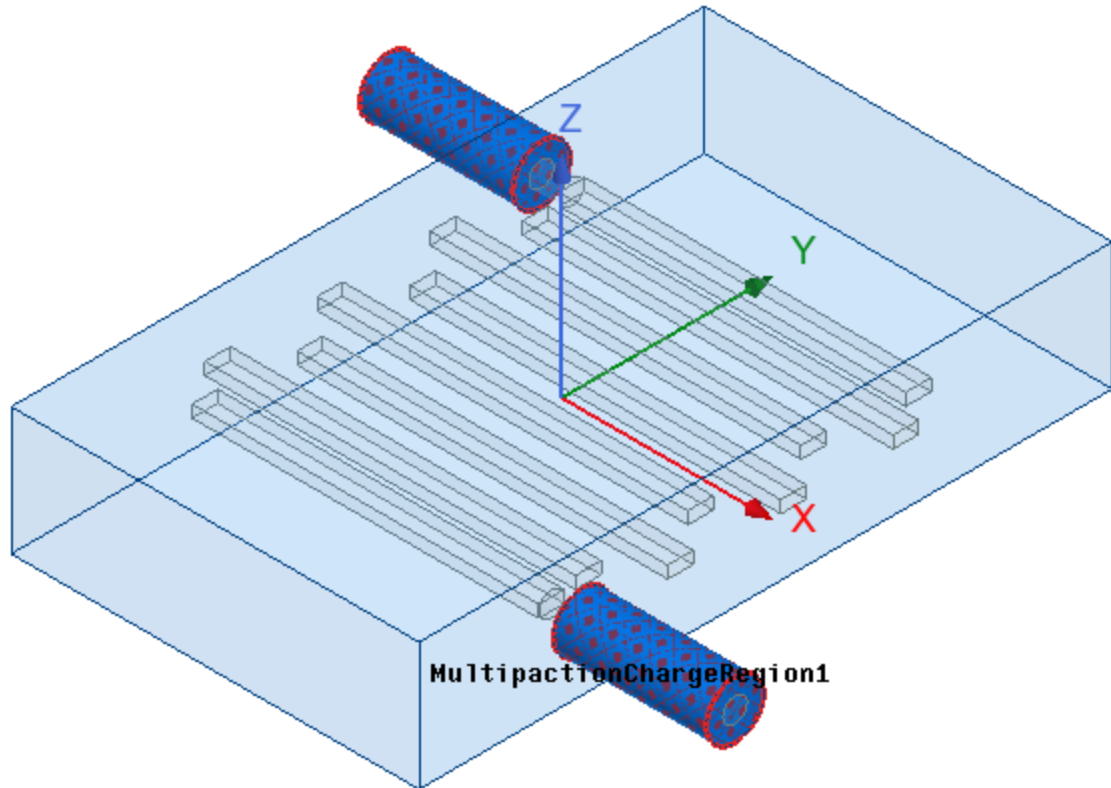

Figure 6-11: Multipaction Charge Region 1 Assigned

3. Select the **Enclosure** object.
4. Using the menu bar, click **HFSS > Excitations > Assign > Multipaction Charge Region**. Then:
 - a. In the *Multipaction Charge Region* dialog box that appears, type **200** in the **Number of particles** text box.
 - b. Ensure that the remaining settings match those shown in the following figure:

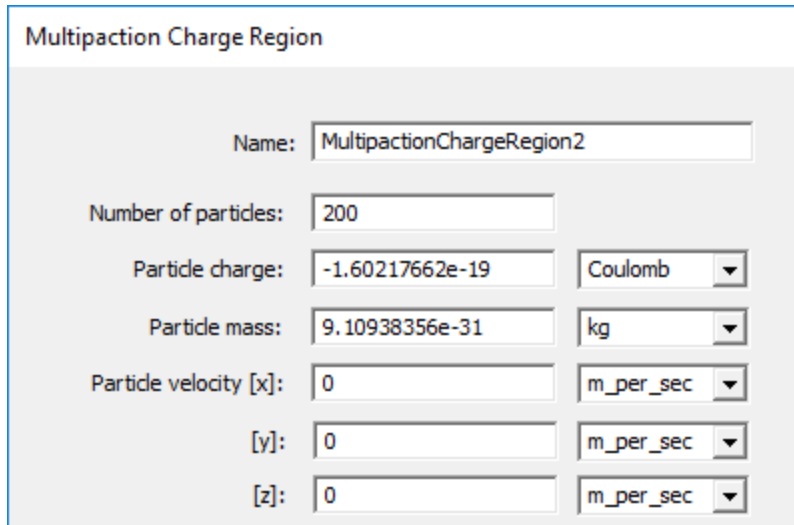

Figure 6-12: Multipaction Charge Region Dialog Box – Settings for Enclosure

- c. Click **OK**.

MultipactionChargeRegion2 appears under *Excitations* in the Project Manager, and the model appearance is as follows:

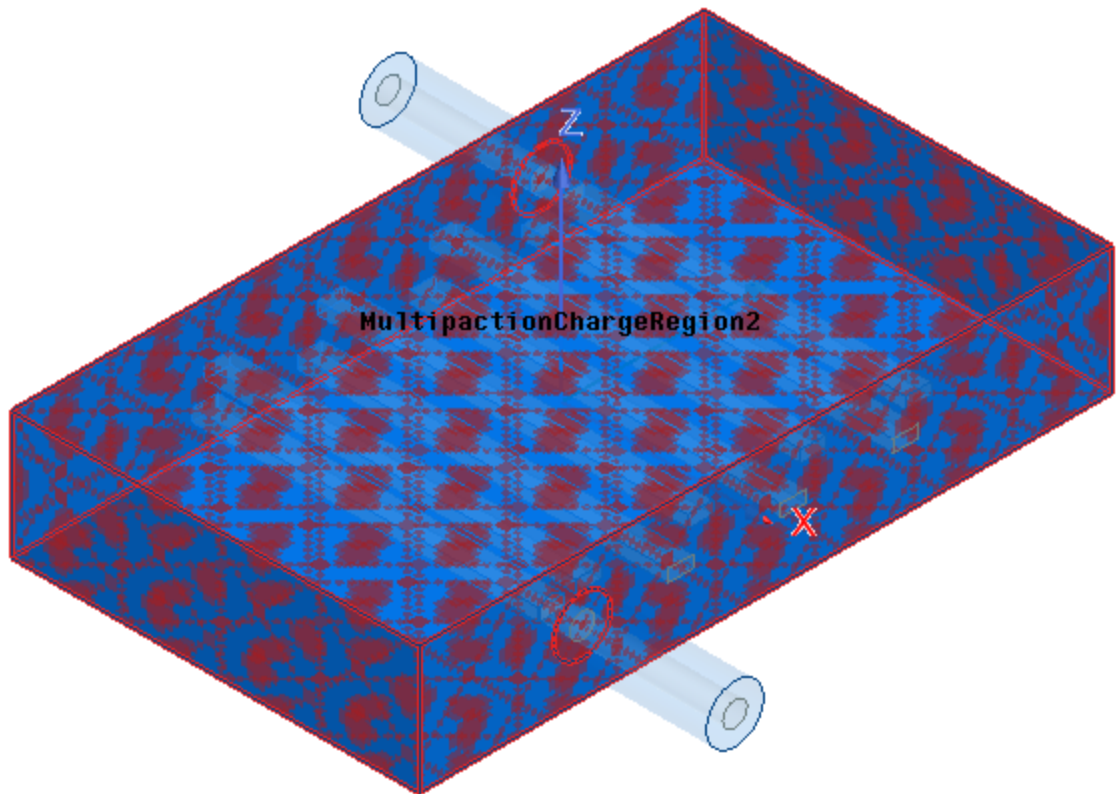

Figure 6-13: Multipaction Charge Region 2 Assigned

5. Click in the background area to clear the current selection.

Add a Discrete Sweep

You will define an additional frequency sweep under analysis *Setup1*. The fields must be saved for the sweep to be used as the basis of a multipaction analysis. It is a common practice to create a separate sweep for this purpose. Saving all fields for a typical frequency sweep would greatly increase the disk space requirement, since there are generally many frequency points solved to create smooth S-parameter plots.

For multipaction purposes, three frequency points are generally adequate to cover the range of a bandpass filter (one near the beginning, one at the middle, and one near the end of the bandpass frequency range). However, for the purpose of this exercise, you will define a single-point discrete sweep (1.5 GHz) and review the results for that one frequency.

1. Under *Analysis* in the Project Manager, right-click **Setup1** and choose **Add Frequency Sweep** from the shortcut menu.
2. In the *Edit Frequency Sweep* dialog box that appears, do the following:
 - a. Specify **M_Sweep** as the **Sweep Name**.
 - b. Choose **Discrete** from the **Sweep Type** drop-down menu.
 - c. Click the **Distribution** cell and choose **Single Point**.
 - d. Type **1.5GHz** in the **Start** cell.
 - e. Select the **Save Fields** option in the rightmost column of the table.

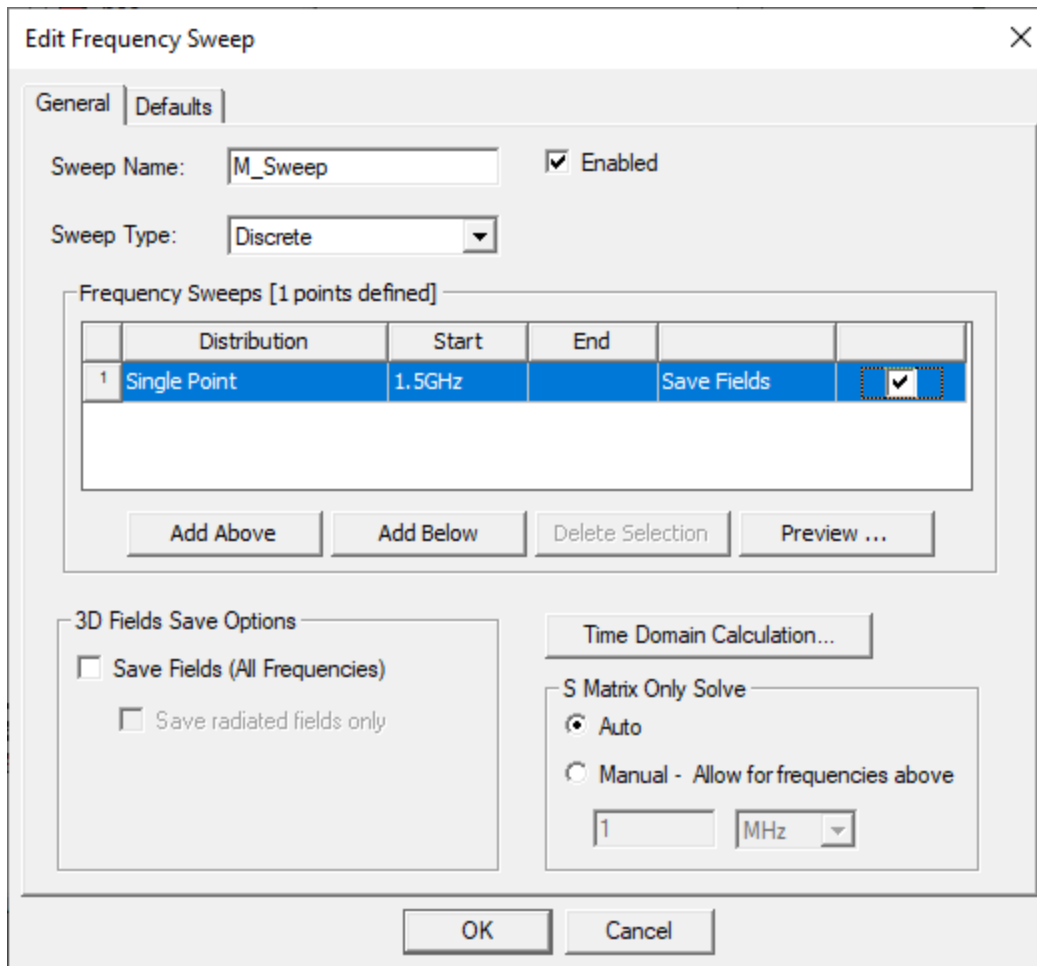

Figure 6-14: Settings for Multipaction Sweep

3. Click **OK** to add the multipaction sweep.

M_Sweep appears under *Analysis > 1p5GHz* in the Project Manager:

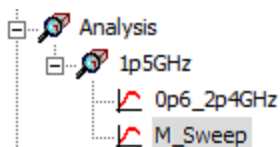

Figure 6-15: M_Sweep in the Project Manager

Add and Solve a Multipaction Analysis

A multipaction solution is transient. When setting one up, you will define a power sweep, stop time (event duration), the maximum number of particles, analysis options, and you will set up the link to the frequency sweep to be used as the basis of the multipaction solution.

1. Under *Analysis > 1p5GHz* in the Project Manager, right-click **M_Sweep** and choose **Add Multipaction Analysis** from the shortcut menu.

2. In the *Multipaction Analysis Setup* dialog box that appears, do the following:

- a. Shorten the **Name** to **Multipaction** (deleting the "1").

In a later step, you will duplicate the second design and create a design named *Multipaction2*. This solution setup will be copied to the new design retaining its name. Removing the "1" suffix avoids confusion from the design and solution setup names being numbered differently.

- b. Choose **Single Point** in the **Distribution** cell.
- c. Type **100** in the **Start** cell. This is the first power multiplier to be analyzed.
- d. Click **Add Below** *three* times so that the *Power sweep points* table has four rows.
- e. Change the **Start** value for rows 2, 3, and 4 to **200, 400, and 800**, respectively.
- f. Specify a **Stop time** of **6 ns**.
- g. Ensure that **Fast multipaction analysis** is selected and also select the **Charge distribution** option to enable particle overlays.

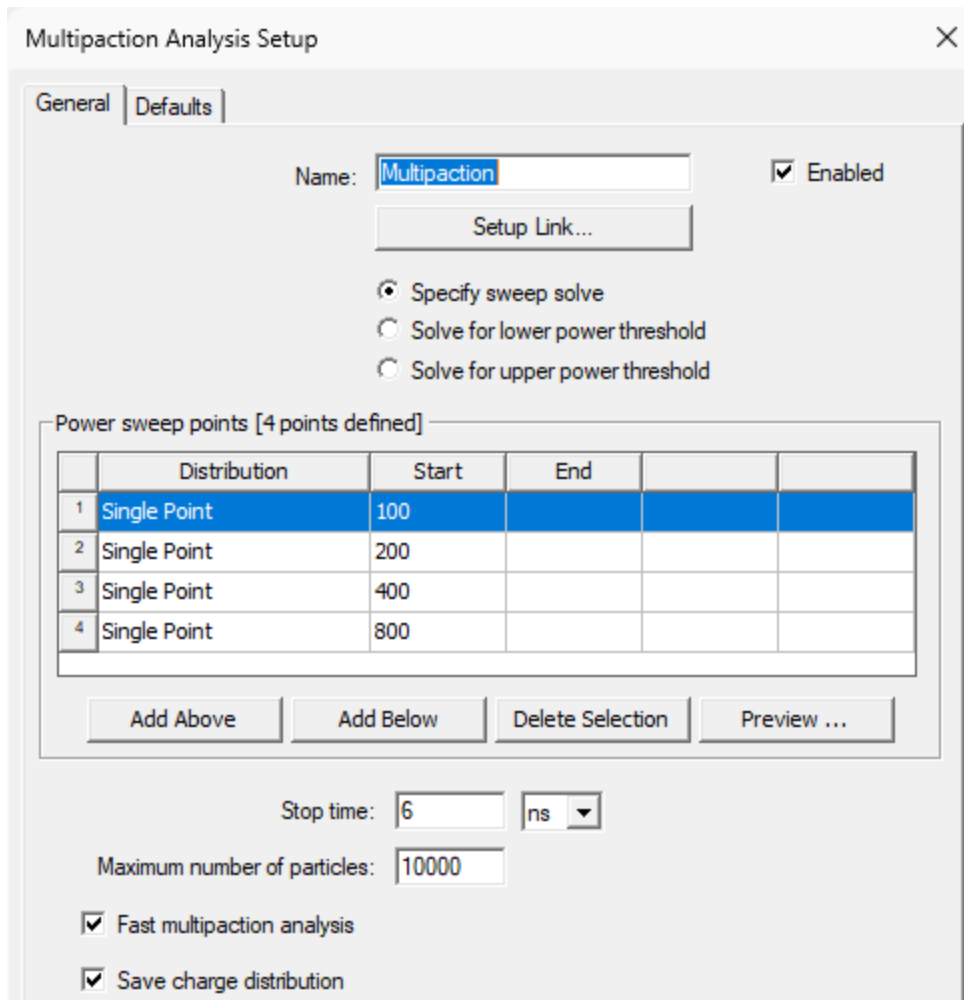

Figure 6-16: Multipaction Analysis Settings

Keep this dialog box open and proceed to the next step.

3. Near the top of the dialog box, click **Setup Link**.
4. In the Setup Link dialog box that appears, do the following:
 - a. Select the **Simulate source design as needed** option.
 - b. Ensure that all settings match those shown in the following figure:

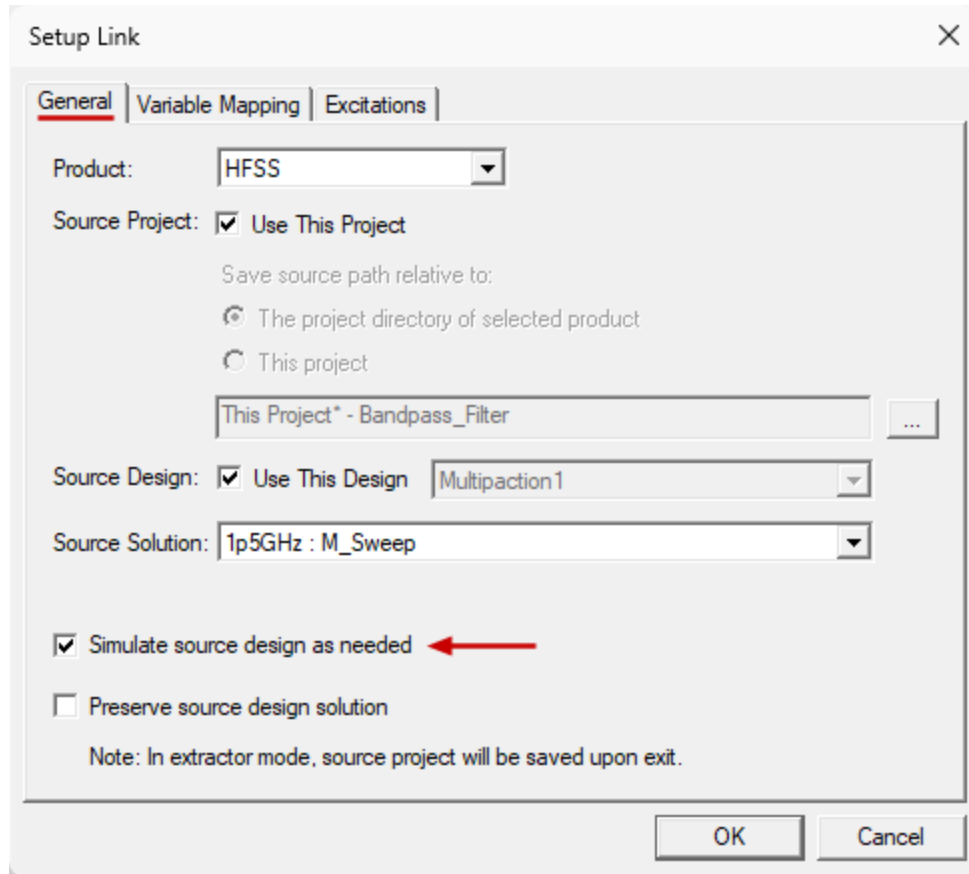

Figure 6-17: Setup Link Settings – General Tab

Since *1p5GHz* and *M_Sweep* are the only analysis setup and sweep that are applicable to a multipaction analysis, the *Product*, *Source Project*, *Source Design*, and *Source Solution* settings should already be populated with the appropriate selections.

5. Select the **Excitations** tab of the *Setup Link* dialog box. Then:
 - a. Select the **Include** checkbox for the 1.5 GHz frequency.

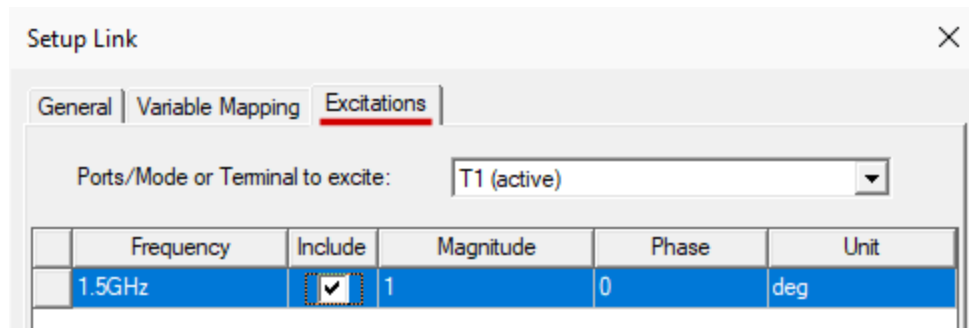

Figure 6-18: Setup Link Settings – Excitations Tab

Note:

If the multipaction sweep contains multiple frequencies, and you include two or more of them in the Setup Link dialog box, the excitations will be combined. That is, the frequencies will be applied simultaneously resulting in a very different waveform as compared to a single excitation frequency.

More typically, unless you are truly exciting the device with multiple frequencies simultaneously, you will want to create multiple multipaction analysis setups, each based on a single excitation frequency.

- b. Click **OK** to close the *Setup Link* dialog box.
6. Click **OK** to complete the multipaction analysis setup.

Multipaction appears under *Analysis* in the Project Manager:

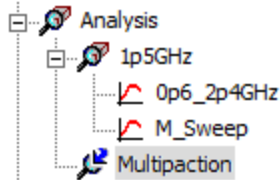

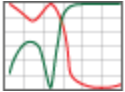

Figure 6-19: *Multipaction* Added to Project Manager

7. Right-click **Multipaction** and choose **Analyze**.
1p5GHz will be re-solved, since the original adaptive solution results were not copied to the second design when you duplicated the first one. The solutions of *M_Sweep* and *Multipaction1* will also be completed.
8. Optionally, under *Analysis* > *1p5GHz* in the Project Manager, right-click **Op6_2p4GHz** and click **Analyze** to restore the frequency sweep results of the original HFSS simulation (those used for the S-Parameter plots).
9. If E Field color contours and the corresponding legend appear on the model (defined for the first design), do the following:
 - a. Under *Field Overlays* > *E Field* in the Project Manager, right-click **Mag_E vs. Frequency** and clear the **Plot Visibility** option.
 - b. Do the same for the **Mag_E vs. Phase** overlay.

Plot Particles versus Time

1. On the **Results** ribbon tab, click  **Multipaction Report** >  **2D**.
2. In the *Report* dialog box that appears, verify the default settings in the **Traces** tab, which are shown in the following image:

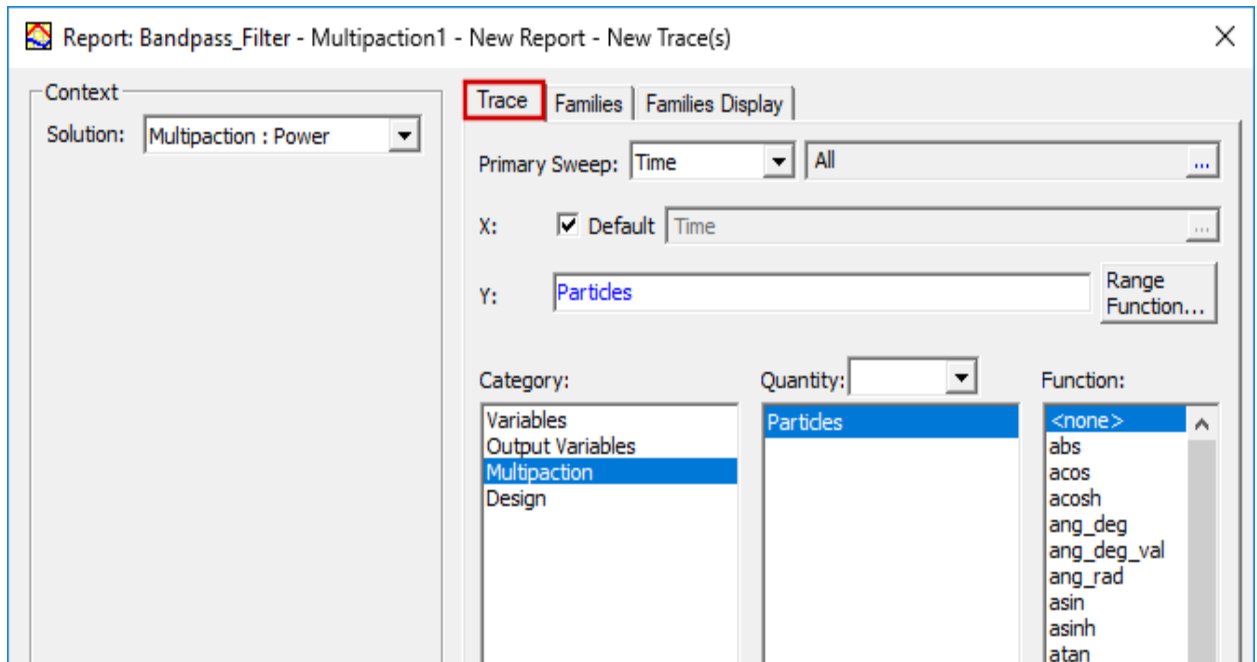

Figure 6-20: Multipaction Report Settings – Traces Tab

3. Select the **Families** tab and ensure that **All** is specified for the **PowerMultiplier** variations:

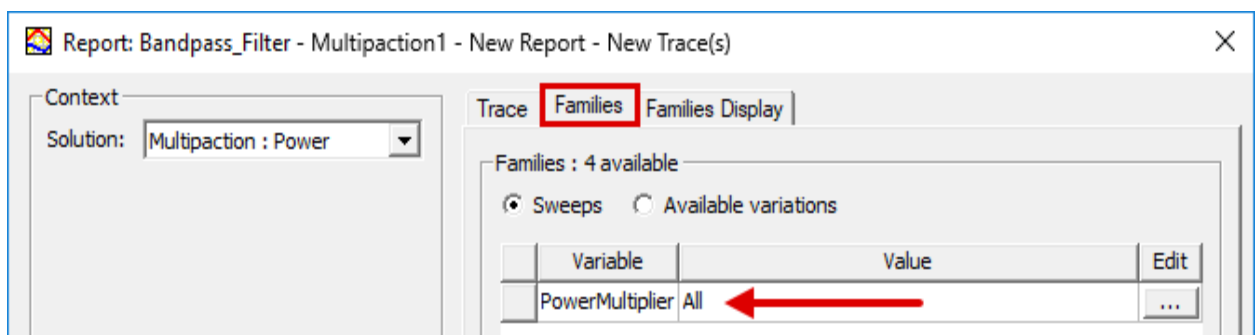

Figure 6-21: Multipaction Report Settings – Families Tab

4. Click **New Report** and then **Close** the dialog box.

The *Multipaction Plot 1* window appears.

5. Under *Results* in the Project Manager, select **Multipaction Plot 1**.

- In the docked *Properties* window, change the plot **Name** to **Multipaction Plot - Zero DC Bias** and press **Enter**.

The plot should resemble the following figure:

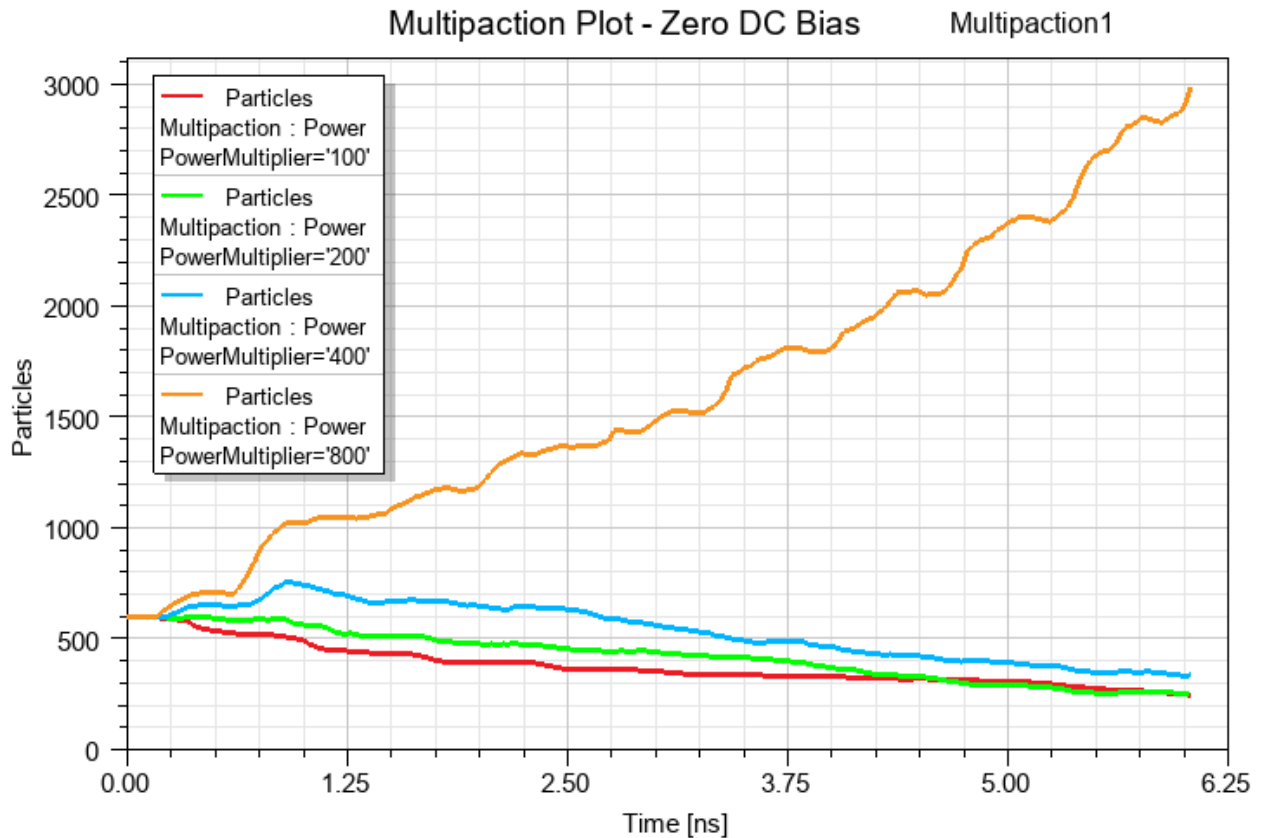

Figure 6-22: Multipaction Plot, Particles vs. Time - No DC Bias Applied to Model

Observations:

For a power multiplier of 800, the particle count increases with time. For a multiplier of 400, there is an initial increase in particle count, but the number decreases gradually beyond 1 ns.

In a later procedure, you will create a duplicate of the second design design but apply a 1000 gauss DC bias to the vacuum objects to suppress multipaction. You will then compare the particles versus time plots of the second and third designs.

Create and Animate a Particle Overlay

Next, you will create a particle overlay, choosing the highest power multiplier and the 6 ns time point. These are the parameters that will produce the greatest particle count.

1. Select the **Enclosure**, **Feed1**, and **Fee1_1** vacuum objects.
2. Right-click **Field Overlays** in the Project Manager and choose **Plot Particles** from the shortcut menu.
3. In the *Create Particles Plot* dialog box that appears, do the following:
 - a. Choose **800** from the **Power** drop-down menu.
 - b. Choose **6e-09s** from the **Time** drop-down menu.

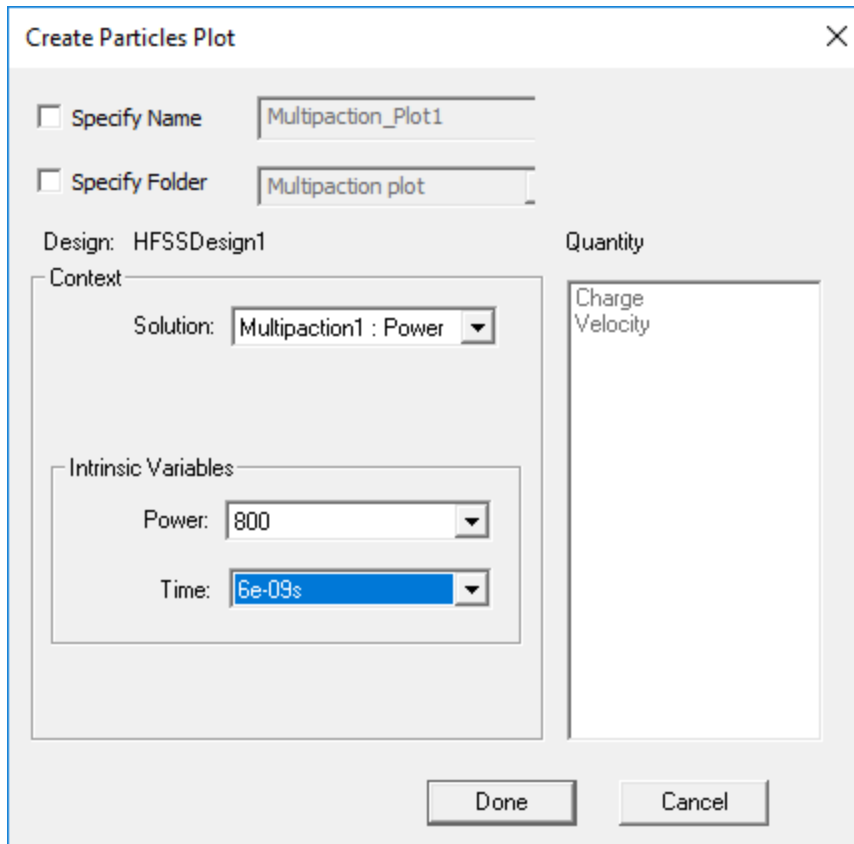

Figure 6-23: Create Particles Plot Dialog Box

4. Click **Done**.
5. Click in the Modeler window background area to clear the current selection.

The particle overlay should resemble the following figure:

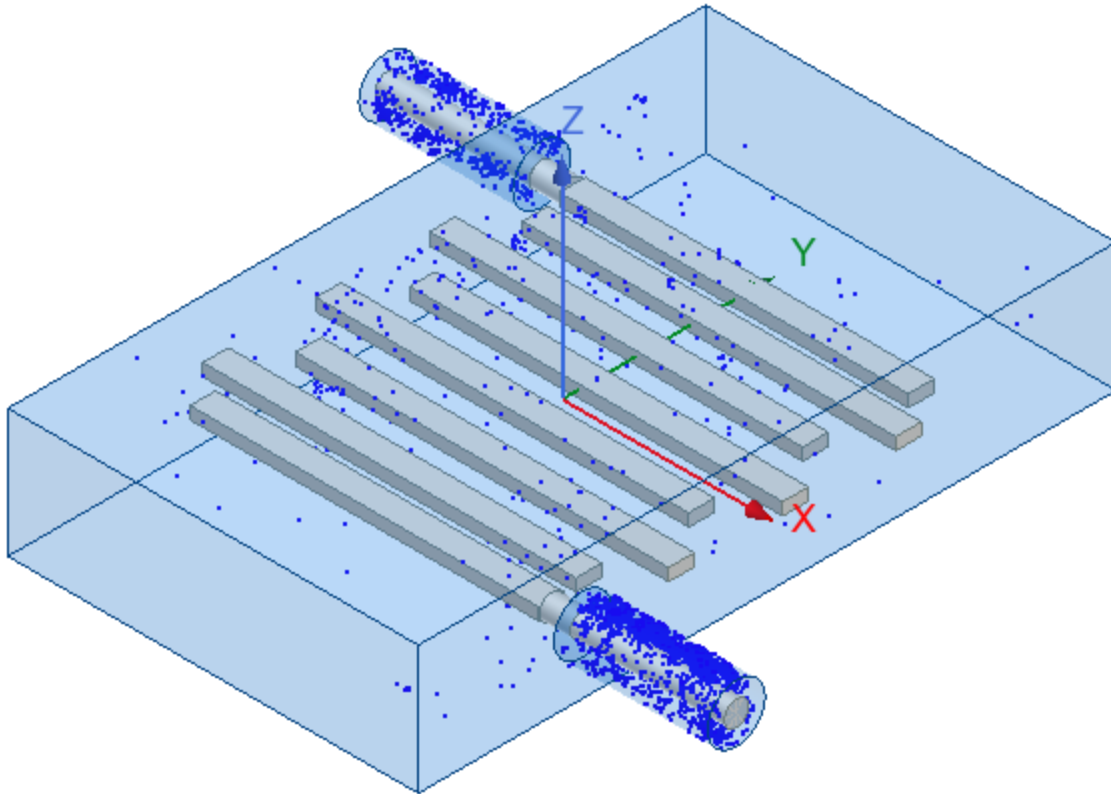

Figure 6-24: Particle Overlay – PowerMultiplier = 800, Time = 6 ns

6. Under *Field Overlays > Multipaction plot* in the Project Manager, right-click **Multipaction_Plot1** and choose **Animate**.

The *Create Animation Setup* dialog box appears.

There is only one variable available as a basis of the animation, **Time**. All time points are selected by default.

7. Select the 0s time point, which will clear the selection of all other time values.
8. Holding **Ctrl**, also select every third time point up to and including 6e-9s (1e-10s, 2e-10s, 3e-10s, ..., 5.9e-9s, 6e-9s).

The dialog box should look like the following figure:

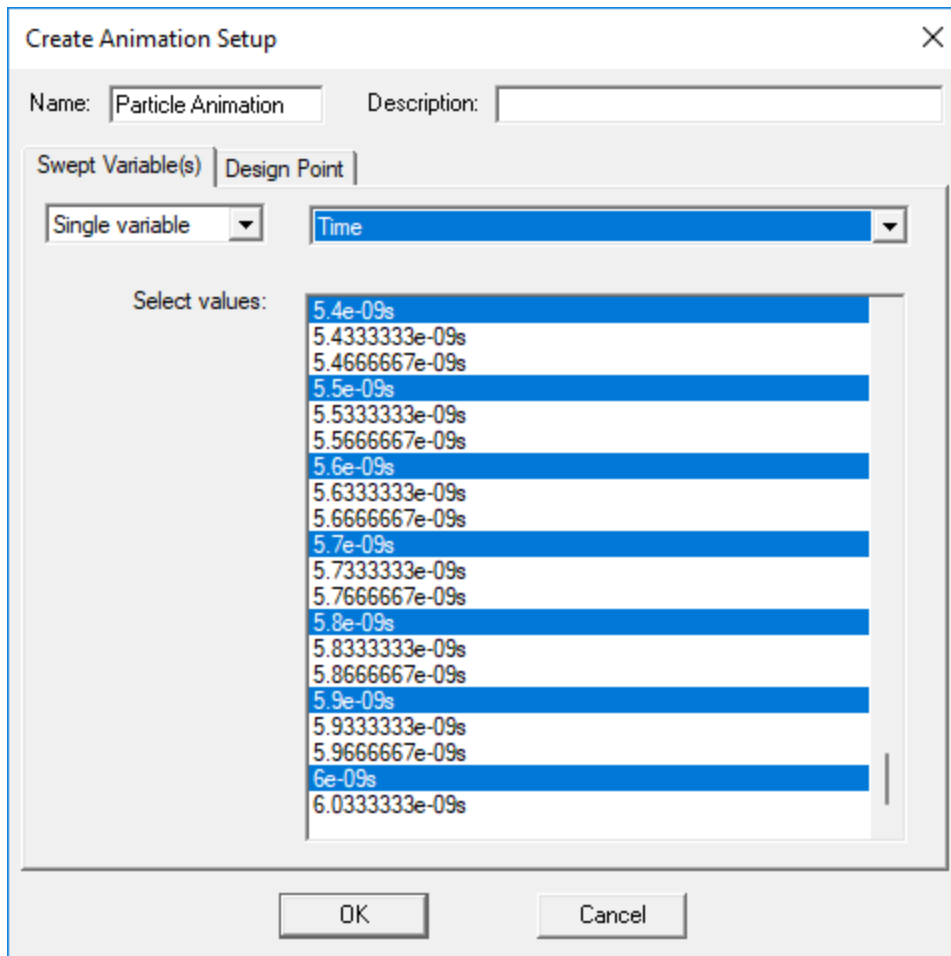

Figure 6-25: Create Animation Setup Dialog Box

Choosing only the time values with zero or one decimal place makes it easier to follow the time annotation that appears while the overlay is animated.

9. Click **OK** to accept the settings and start the animation.
10. Use the available *Animation* controls to start, stop, reverse, or adjust the speed of the animation.

Your animated overlay should resemble the following video clip:

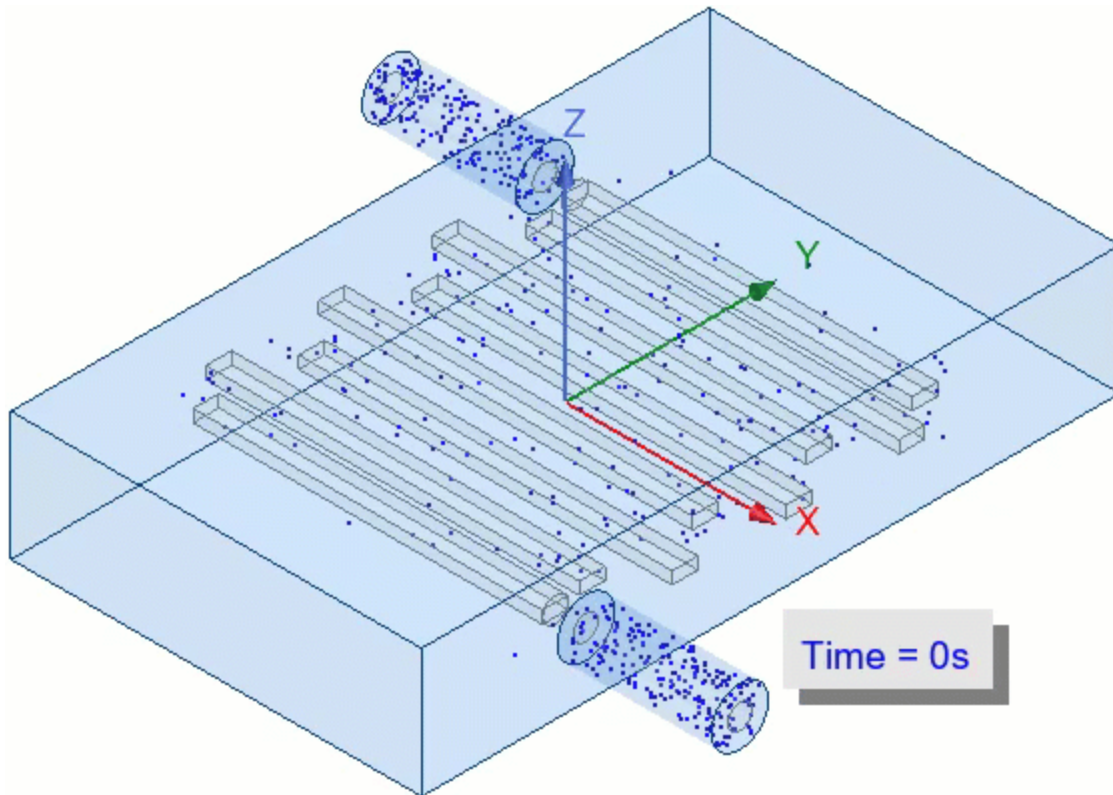

Figure 6-26: Particle Overlay Animation – PowerMultiplier = 800

Observations:

A proliferation of particles is easily seen in the feed regions. By comparison, the increase in particles within the enclosure is relatively minor but still observable.

Duplicate Multipaction Design and Add DC Bias

You will apply a DC magnetic bias of 1000 gauss (G) to the three vacuum objects to suppress multipaction effects. Before doing so, you will create a duplicate of design *Multipaction1* to preserve the results of the zero-bias case.

The magnetic bias is specified in units of electrical current / distance, specifically A/m. The conversion factor for converting G to A/m is $1000 / (4\pi)$. You will specify the magnetic field in the X-direction. Therefore, the magnetic bias you assign will be as follows:

$$H_x = 1000 \text{ G} \left[\frac{1000}{4\pi} \text{ A/(m} \cdot \text{G)} \right] = 79,577.5 \text{ A/m}$$

We can round that result up to the nearest multiple of ten and call it **79,580 A/m**.

Duplicate the first design and assign the DC bias as follows:

1. Right-click **Multipaction1 (Hybrid Terminal Network)** in the Project Manager and choose **Copy** from the shortcut menu.
2. Right-click the project **Bandpass_Filter** at the top of the Project Manager and chose **Paste**.

Multipaction2 (Hybrid Terminal Network) appears in the Project Manager and becomes the currently active design.

3. In the Project Manager, collapse the **Multipaction1 (Hybrid Terminal Network)** branch and expand the **Multipaction2 (Hybrid Terminal Network)** branch.
4. In the **Window** menu, ensure that **Bandpass_Filter - Multipaction2 - Modeler** is the active window.
5. In the **Object** selection mode, or using the History Tree, select **Enclosure**, **Feed1**, and **Feed1_1**.
6. In the Project Manager, right-click **Excitations** and choose **Assign > Multipaction DC Bias**.
7. In the *Multipaction DC* bias dialog box that appears, do the following:

- a. In the *H Field* section, specify of **Uniform** value of **79580 A_per_m** for **Hx**:

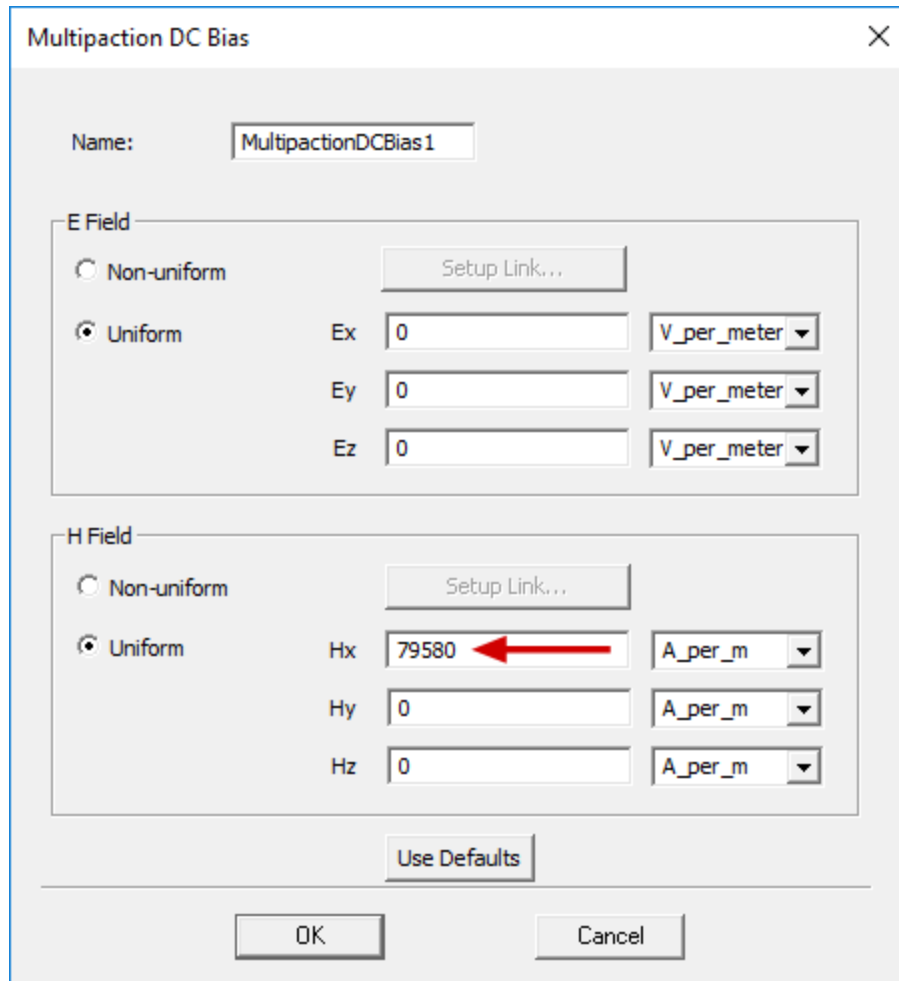

Figure 6-27: Multipaction DC Bias Dialog Box

- b. Click **OK** to assign the specified bias.

With *MultipactionDCBias1* selected under *Excitations* in the Project Manager, the assigned bias is visualized on the model as shown below:

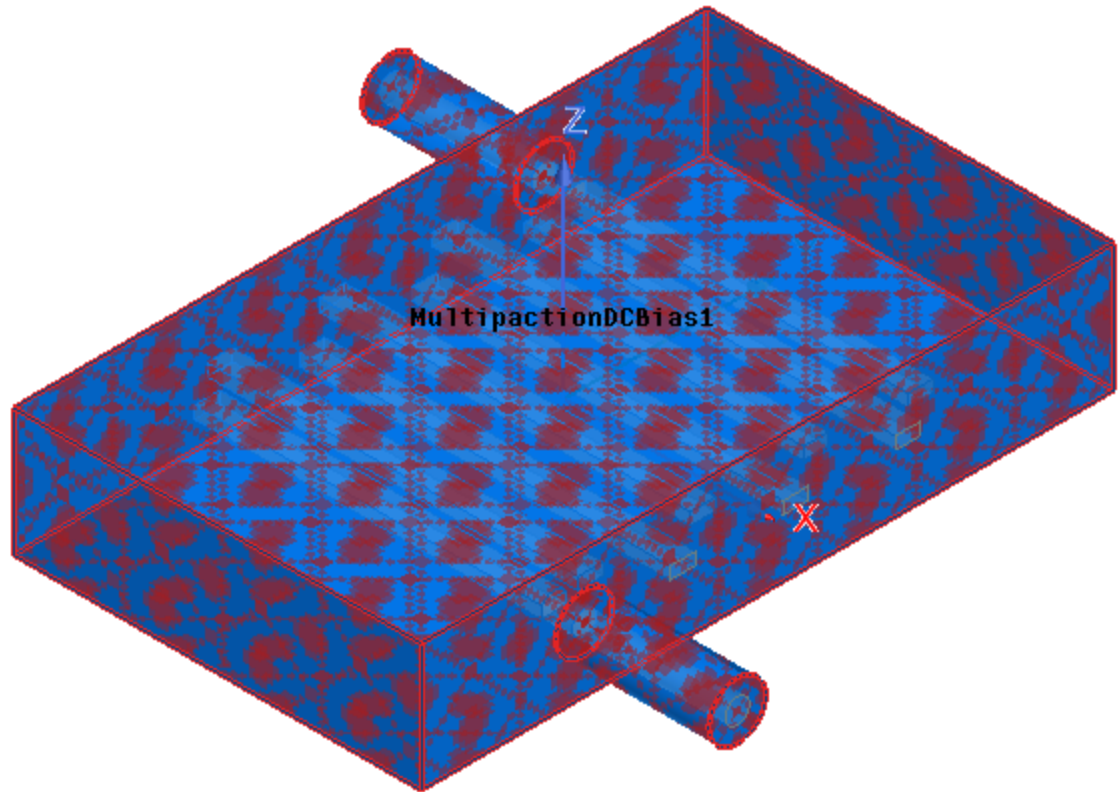

Figure 6-28: Multipaction DC Bias Assigned

Solve Multipaction2 and Compare Results

1. Under *Analysis* in the Project Manager, right-click **Multipaction** and choose **Analyze** from the shortcut menu.

This analysis will typically take less than two minutes to complete.

2. Under *Reports* in the Project Manager, select **Multipaction Plot – Zero DC Bias**.
3. In the docked *Properties* window, change the plot **Name** to **Multipaction Plot – 1000G DC Bias** and press **Enter**.
4. In the Project Manager, double-click **Multipaction Plot – 1000 Gauss DC Bias** to open the plot window, which should resemble the following figure:

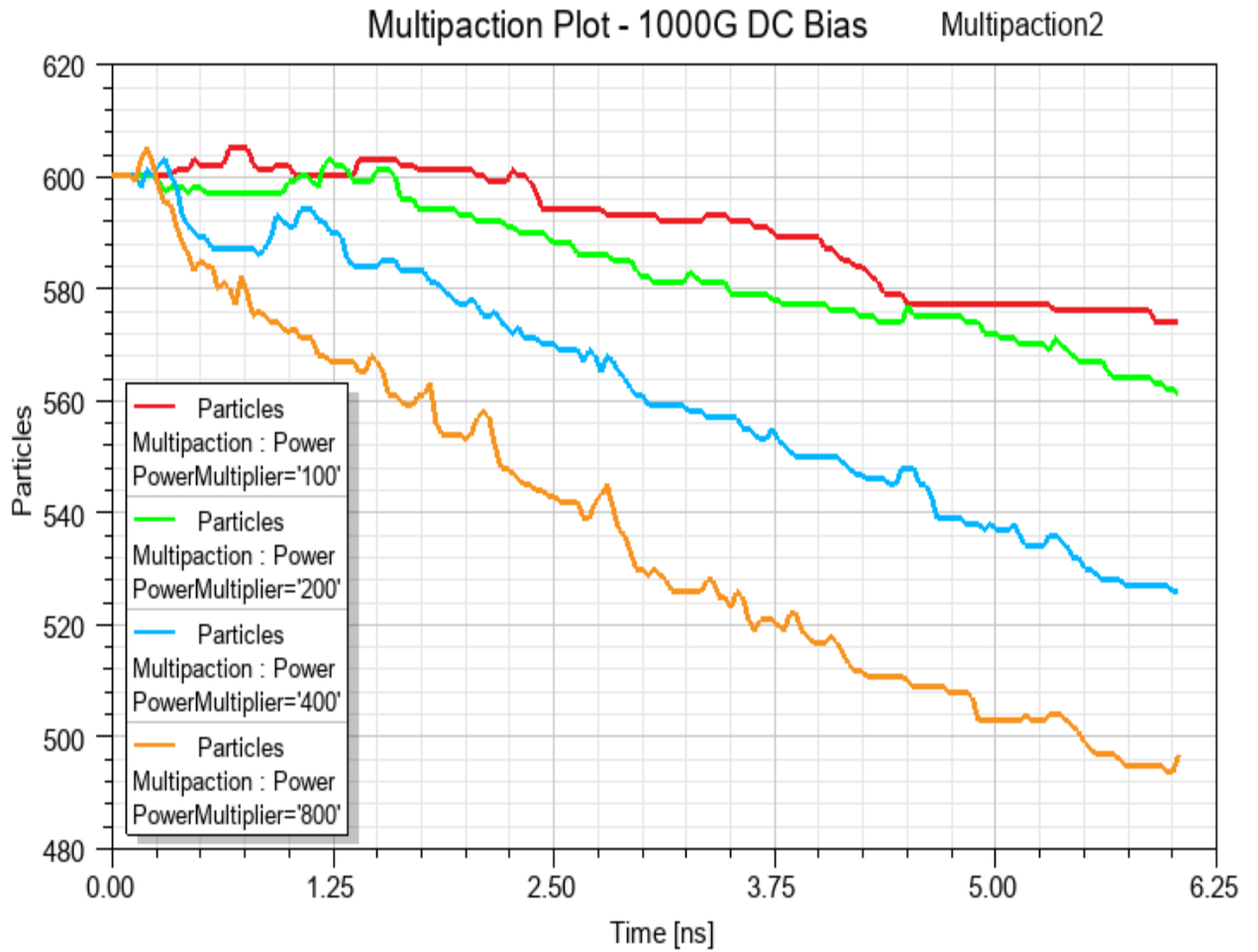

Figure 6-29: Multipaction Plot, Particles vs. Time – 1000 Gauss DC Bias Applied to Model

Compare the preceding plot with the one from the first multipaction analysis. For your convenience, the zero-bias plot is included again in the following figure:

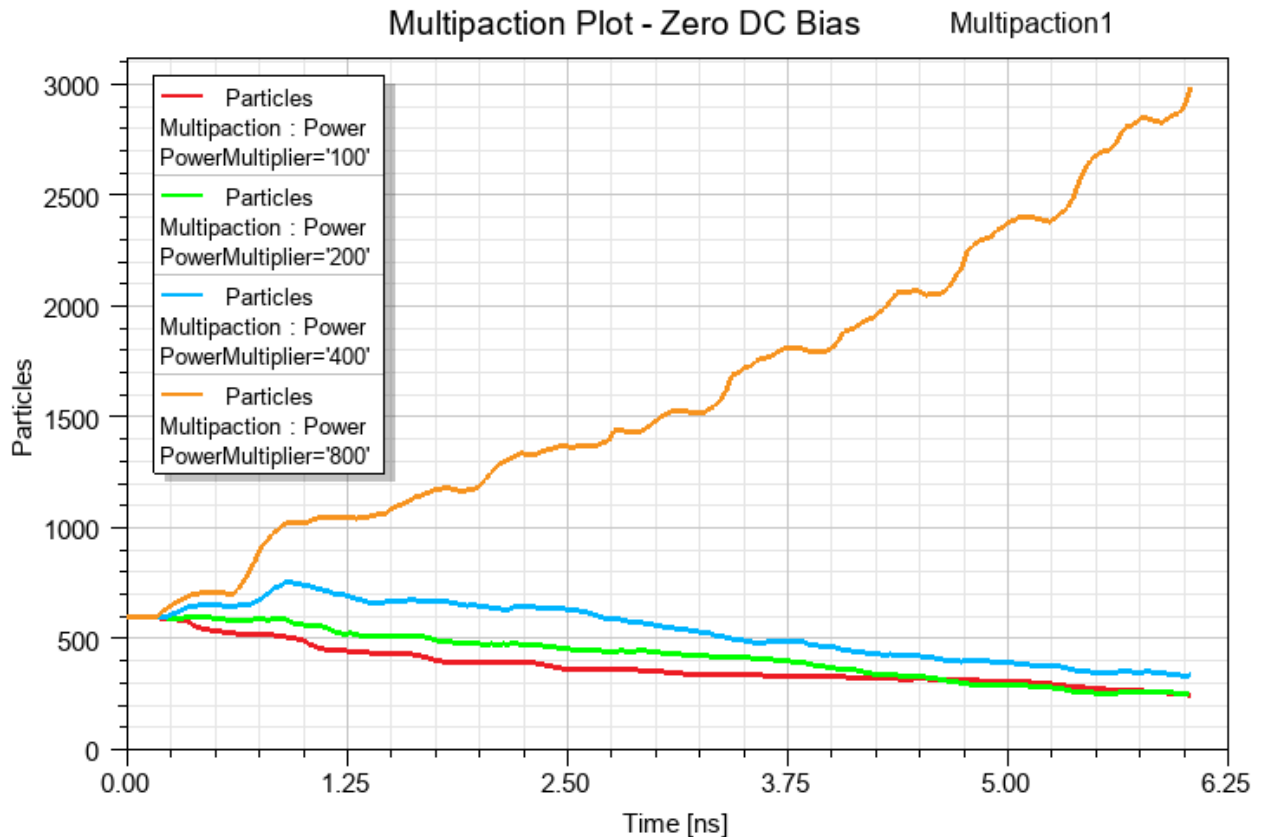



Figure 6-30: Multipaction Plot, Particles vs. Time – No DC Bias Applied to Model

Observations:

- The limited Y-scale range of the *1000G DC Bias* graph is exaggerating the particle count fluctuations relative to the *Zero DC Bias* plot, which has a much greater Y axis range.
- The addition of the 1000G magnetic bias effectively suppresses multipaction for all power multipliers considered in the solution.
- Notice how the DC bias causes the rate of particle dissipation to increase as the power multiplier increases. The lowest particle count at the end of the Multipaction2 simulation occurs for a power multiplier of 800, whereas this trace ended with the highest particle count in the Multipaction1 simulation.
- For power multipliers of 100, 200, and 400, the DC bias causes the particle counts at the end of the simulation to be higher than when no bias was applied. However, no proliferation occurs at any multiplier nonetheless.

5. Optionally, display and animate the particle overlay for the second design.

You will see that the particle count decreases slightly throughout the simulation. The change is easiest to perceive when the play head loops back from 6e-9 ns to 0 ns at the end of the animation, and the higher particle density at the beginning of the animation suddenly appears again.

6.  **Save** your project.

7 - Optionally, Restore Legacy View Orientations

You have completed this getting started guide.

The current view orientation scheme implemented in version 2024 R1 of the Ansys Electronics Desktop application has a few of advantages over the legacy scheme:

- It is more consistent with the majority of Z-up solid modeling software products.
- The identification of front, back, left, and right sides is more intuitive.
- It is better suited to mixed 2D (typically XY) and 3D modeling, with the X axis to the right for Top, Front, Bottom, and Isometric views. Accordingly, the Right side view is the +X side of the geometry now (which was the +Y side for the legacy orientation).

However, many of the HFSS getting started guides, and those for other design types, were written using older software versions. The instructions and images in many of these guides have not been updated to the new orientation scheme. You may be working through multiple guides, or you may have a library of many existing models constructed in a way that is suitable for legacy orientations but perhaps not as suitable for the current orientation scheme. If so, it might be more convenient for you to select the *Use Legacy View Orientation* option.

If you prefer to continue using the legacy view orientations that were applicable to 2023 R2 and earlier versions of the Ansys Electronics Desktop application, select the option as follows:

1. From the menu bar, click **View > Options**.

The *3D UI Options* dialog box appears.

2. Select **Enable Legacy View Orientation**:

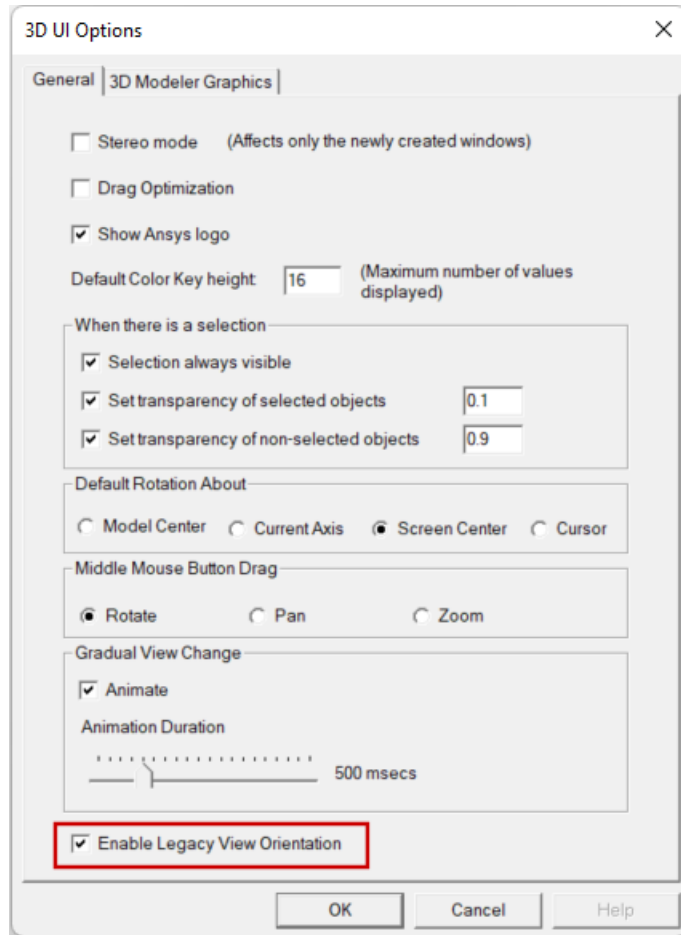

Figure 7-1: 3D UI Options Dialog Box

3. Click **OK**.

Otherwise, leave this option cleared to continue using the newer view orientations going forward.

The settings in the 3D UI Options dialog box are global. Your choice is retained for all future program sessions, projects, and design types that use the 3D Modeler or that produce 3D plots of results.

You can now save and close this project.